

REMOVE AND SAVE
CHAIN GUARD AND
FASTENERS

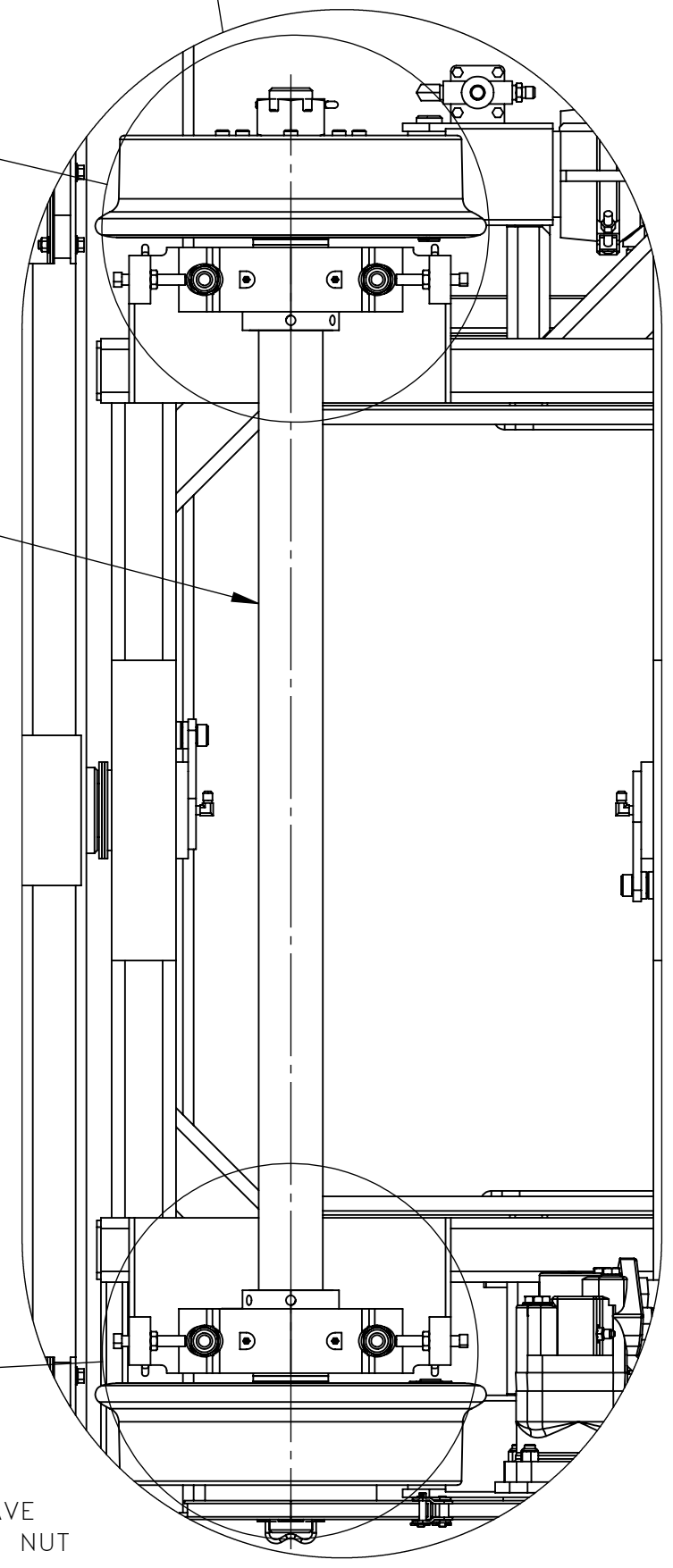

REMOVE 3.0 DIA AXLE
ASSEMBLY

REMOVE 3.0 DIA AXLE
ASSEMBLY

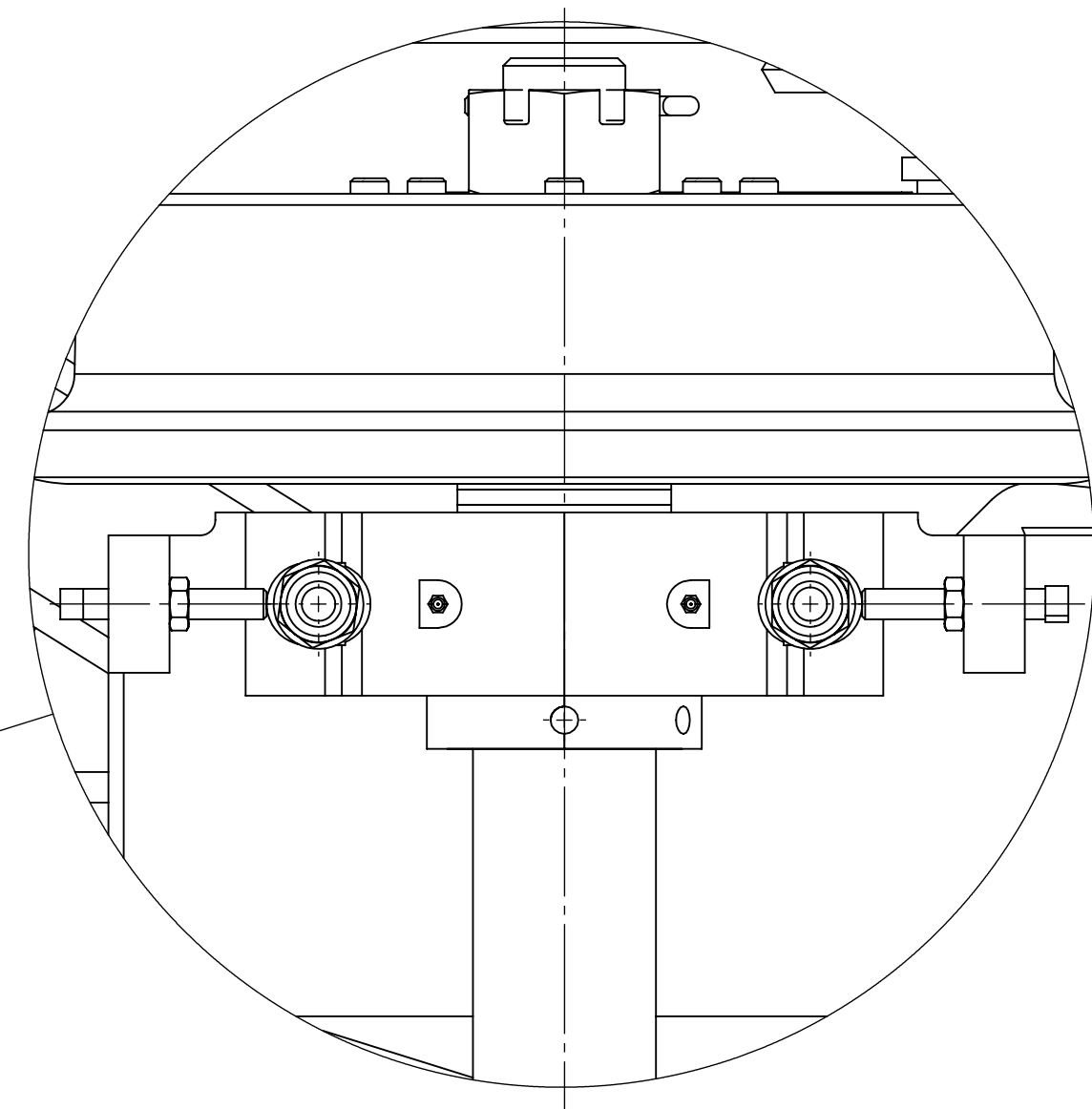
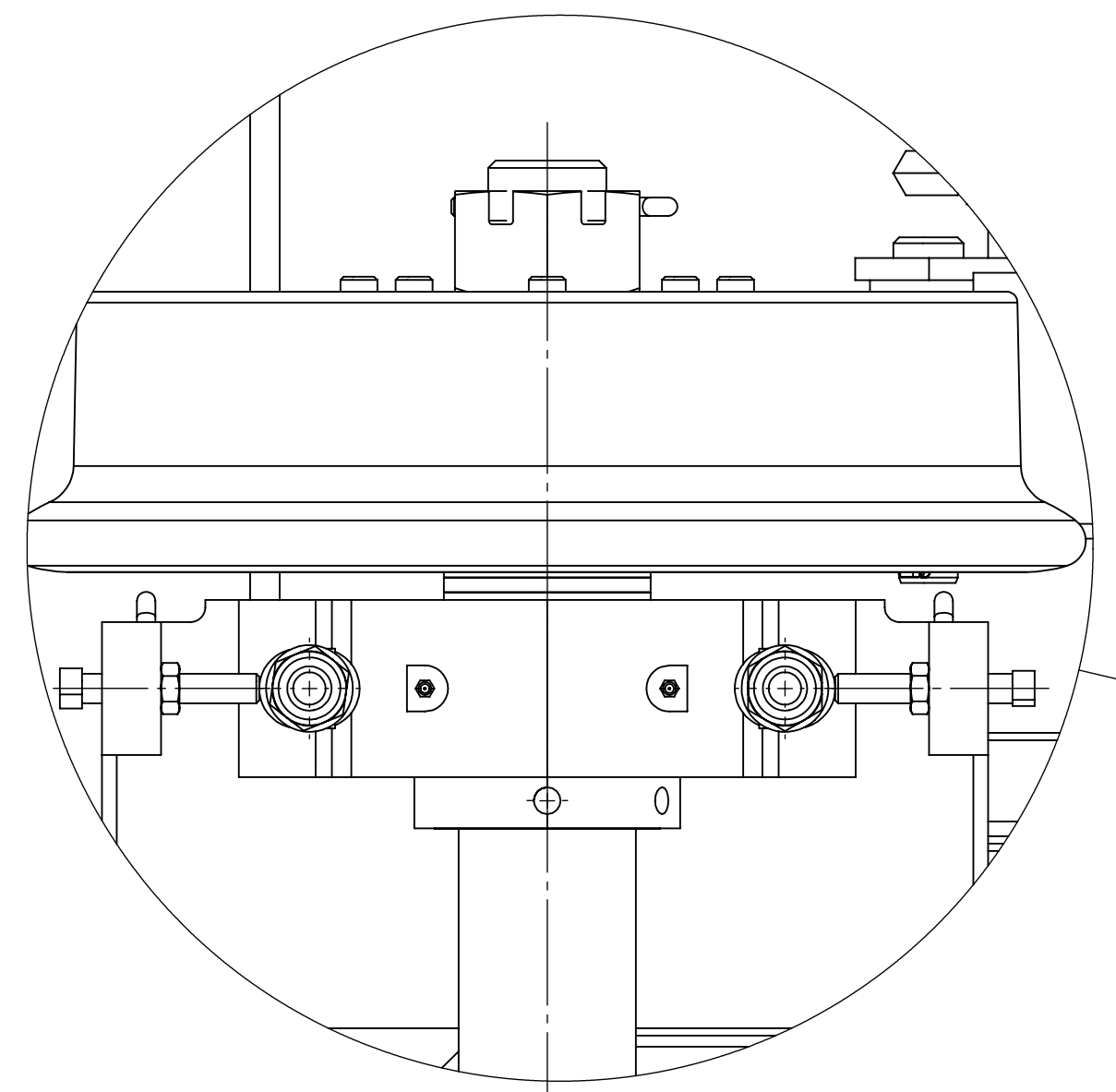
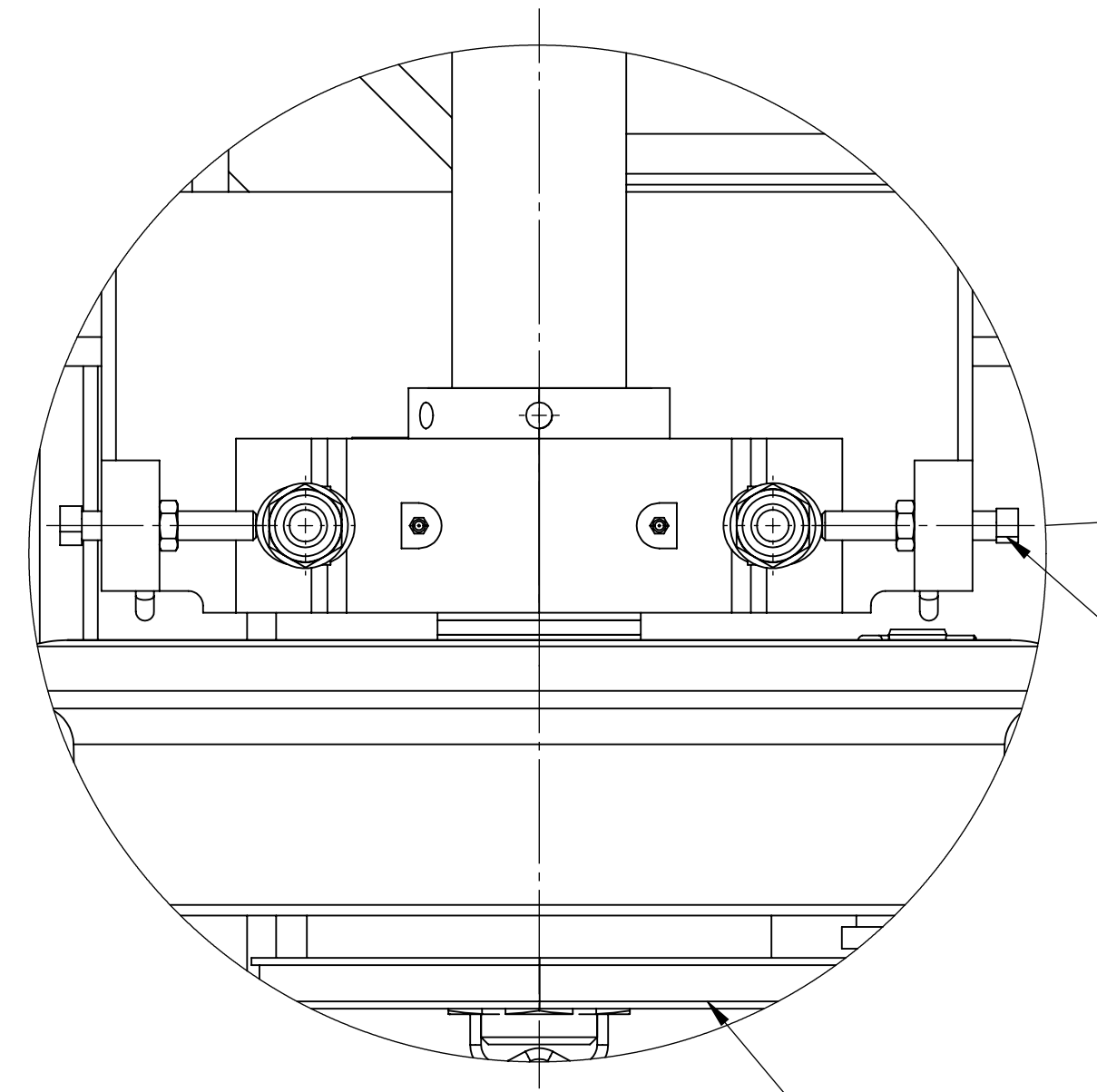
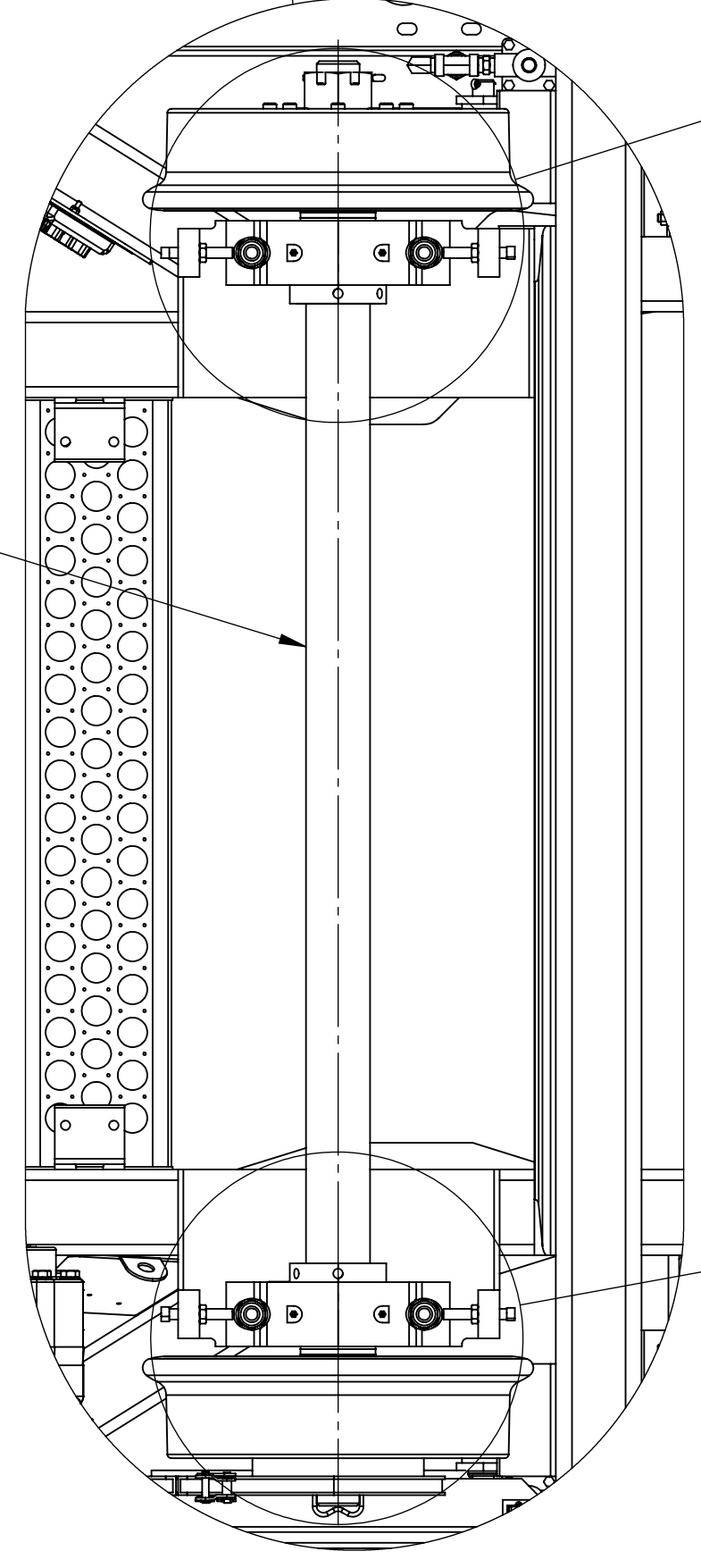

REMOVE AND SAVE
SET SCREW AND NUT
(8 PLCS)

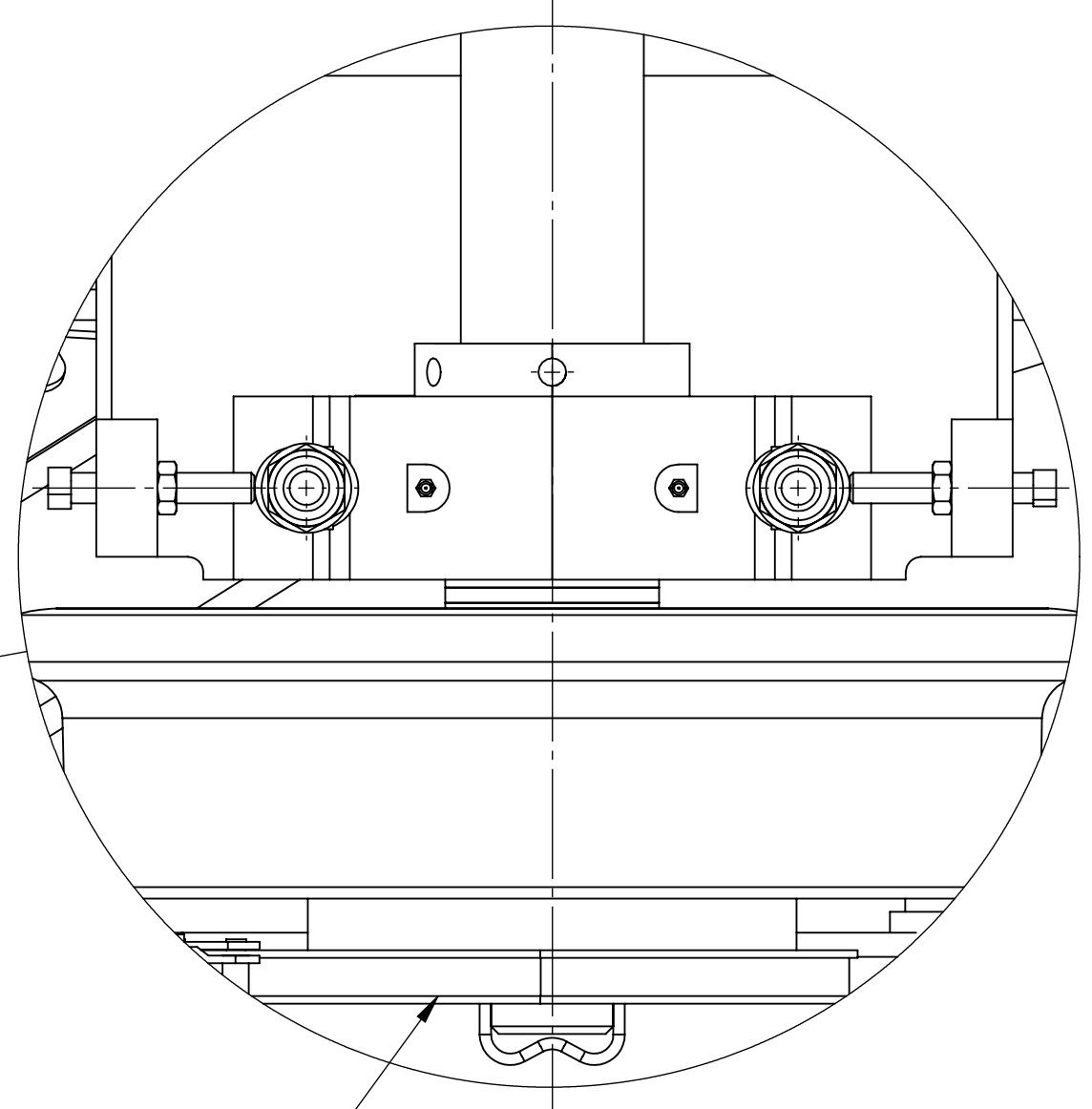

REMOVE AND SAVE
ROLLER CHAIN AND LINK

REMOVE AND SAVE
ROLLER CHAIN AND LINK

STEP 1 - AXLE REMOVAL

REV	EN	DESCRIPTION	DATE	DRN
1	00732	NEW RELEASE	7-24	ASM
DIMENSION TOLERANCES UNLESS OTHERWISE SPECIFIED				
LINEAR	.XX=±.03	.XXX=±.010	KERF ALLOW.	
ANGULAR	X'=±1°	X.X'=±.5°		
SURFACE FINISH		125	SMOOTH ALL SHARP EDGES CLEAN ALL WELDS	
THIS PRINT AND ALL INFORMATION WITHIN BELONGS TO RACINE RAILROAD PRODUCTS				
RACINE RAILROAD PRODUCTS RACINE, WISCONSIN USA				
DESCRIPTION				
INSTRUCTIONS, 3.50 DIA AXLE KIT				
MATERIAL TYPE				
			SEE BOM	
USED ON	935582	SCALE	DATE	
		1:20	07-16-24	
DRN	WEIGHT (LBS)	JOB NO	SHEET	
ASM	17523.99	RD190005	1 OF 5	
DWG SIZE	CATALOG	DWG NO		
D	A		800422	

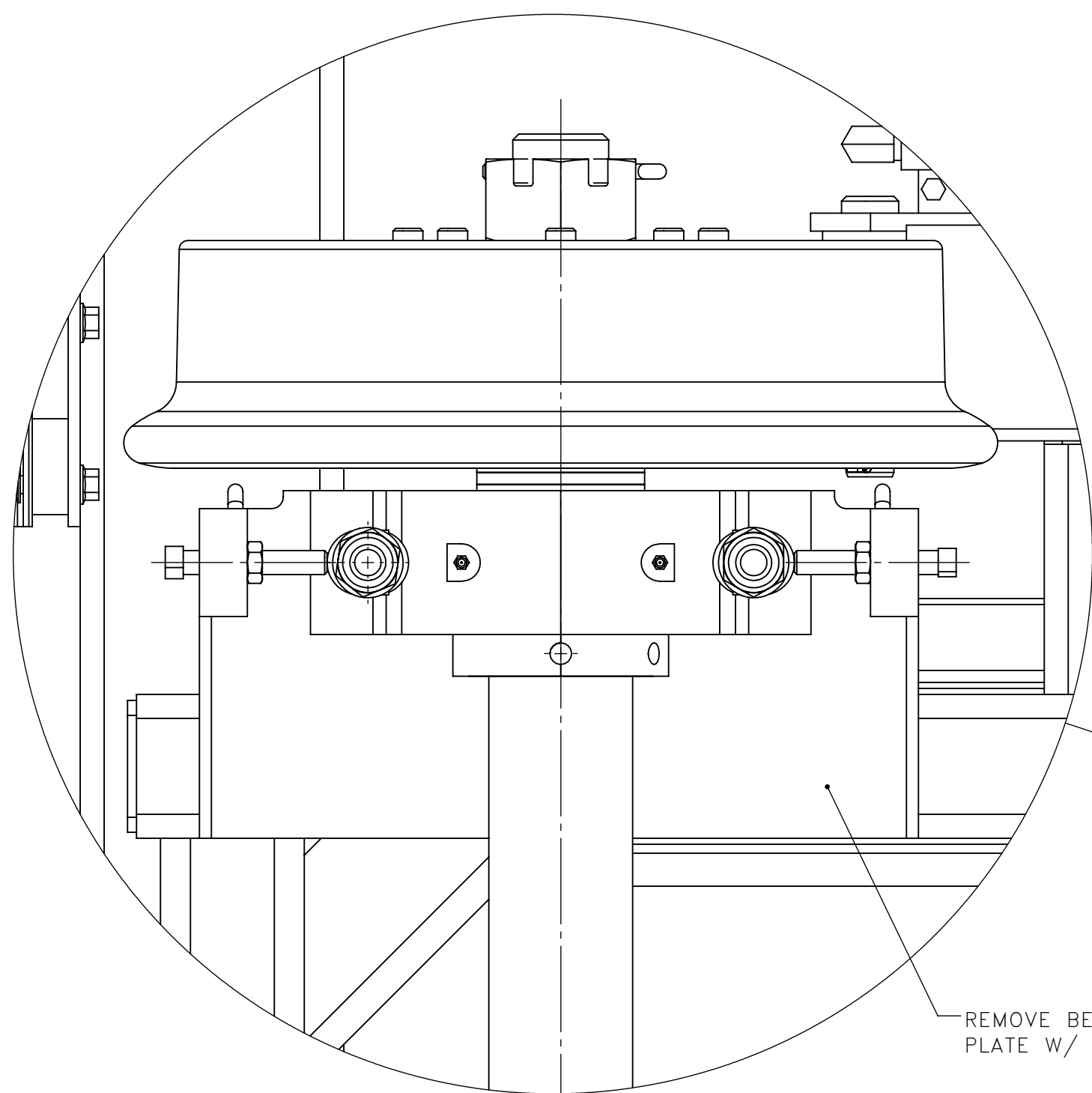

SCALE 1 : 3

REMOVE BEARING MOUNTING PLATE W/ LUGS

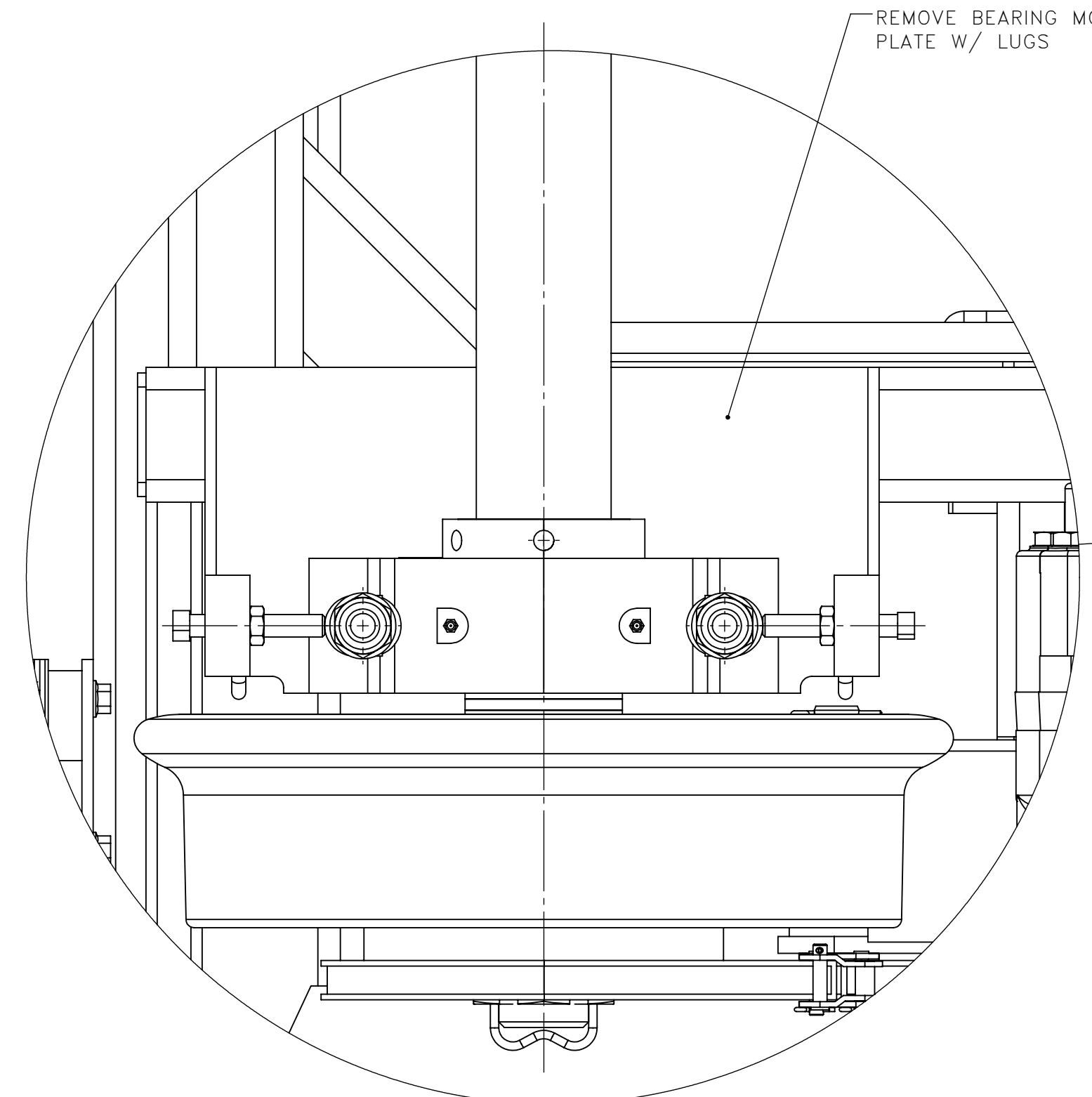

SCALE 1 : 3

REMOVE BEARING MOUNTING PLATE W/ LUGS

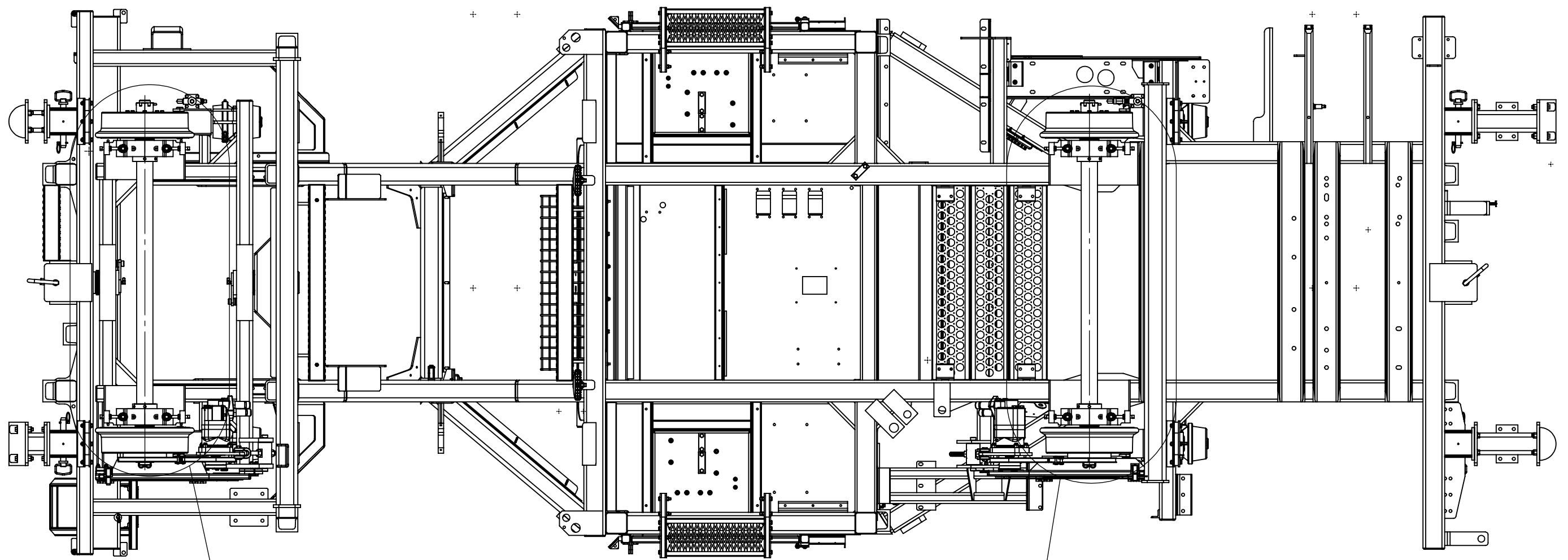

BOTTOM VIEW

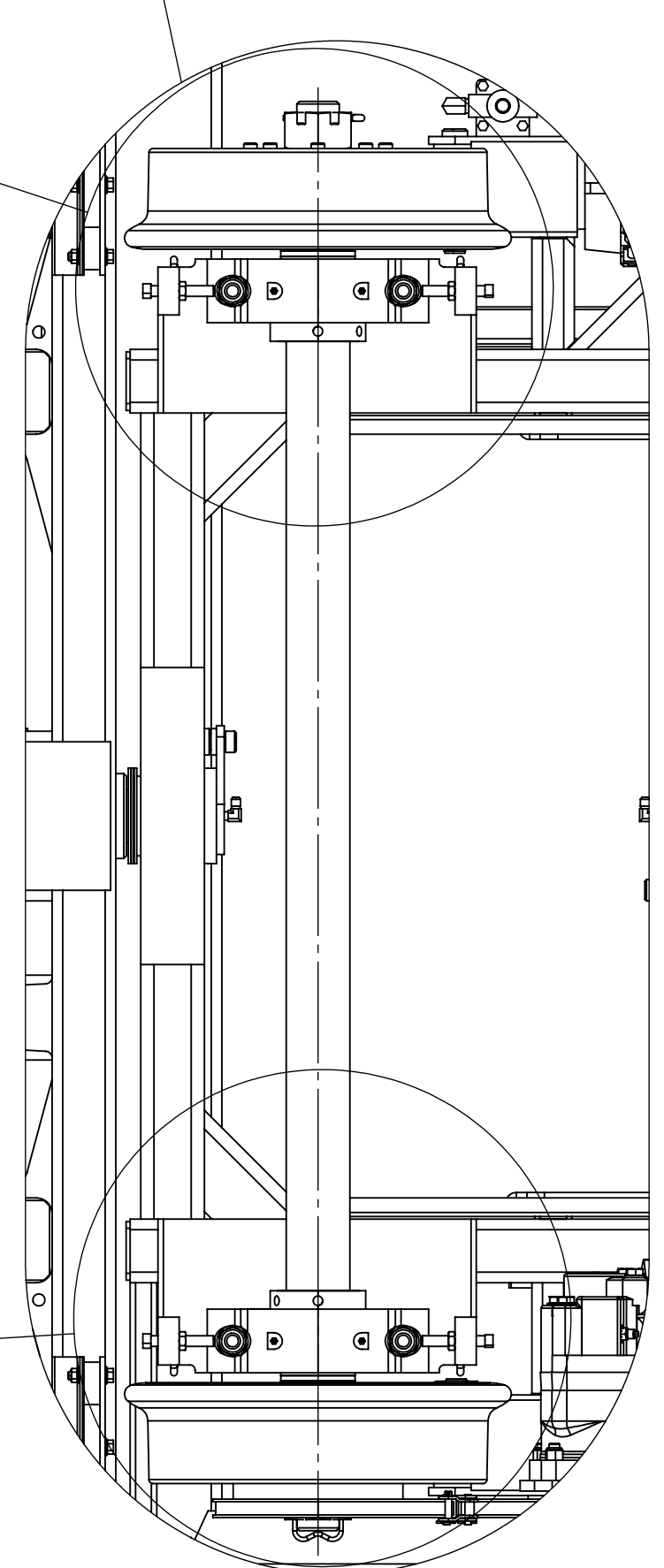

SCALE 1 : 8

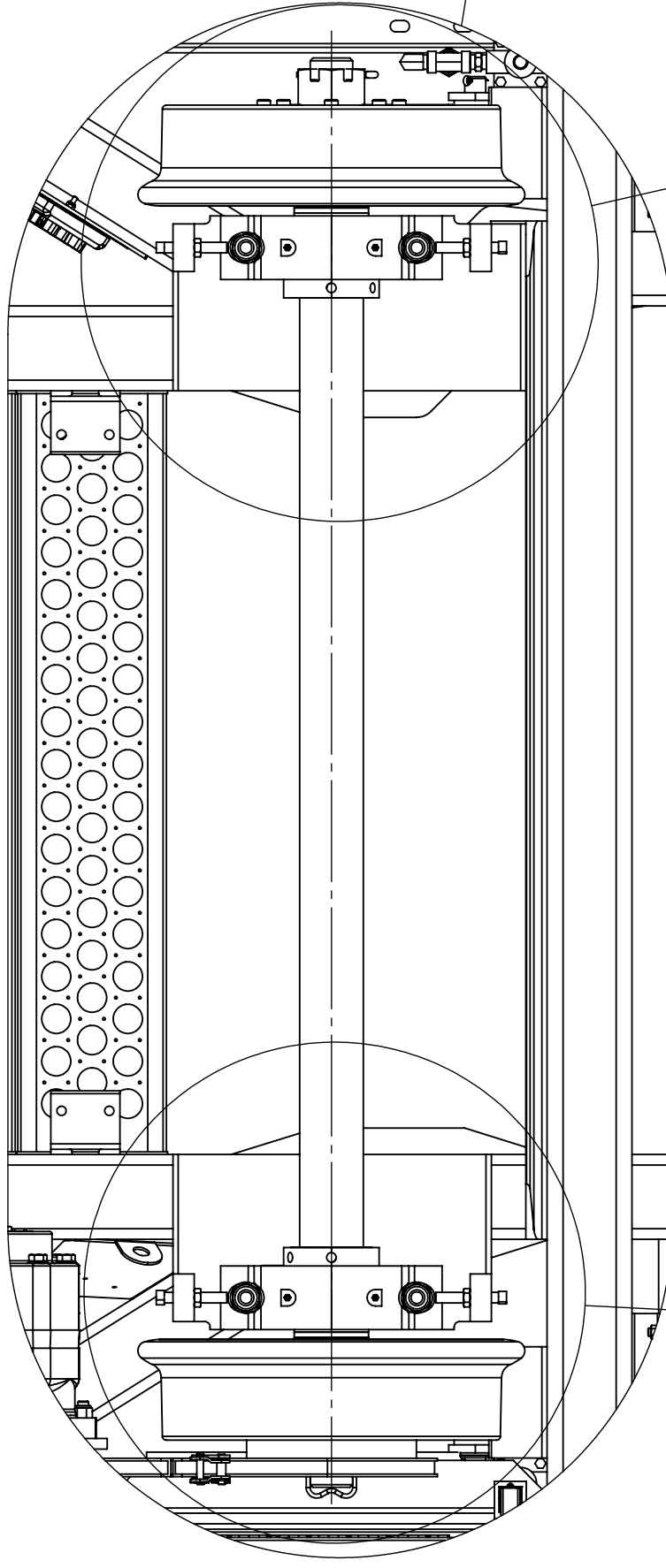

SCALE 1 : 8

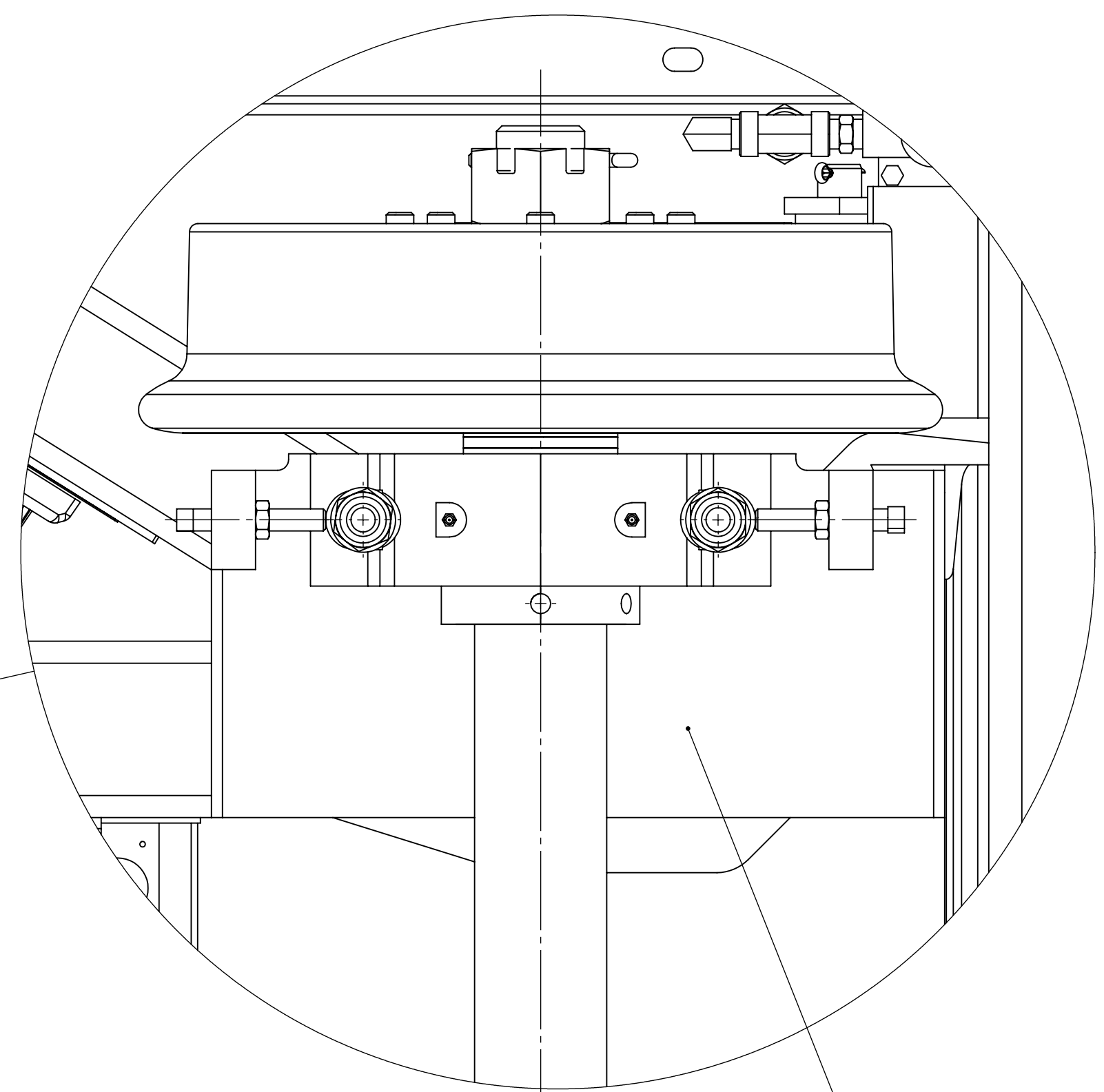

SCALE 1 : 3

REMOVE BEARING MOUNTING PLATE W/ LUGS

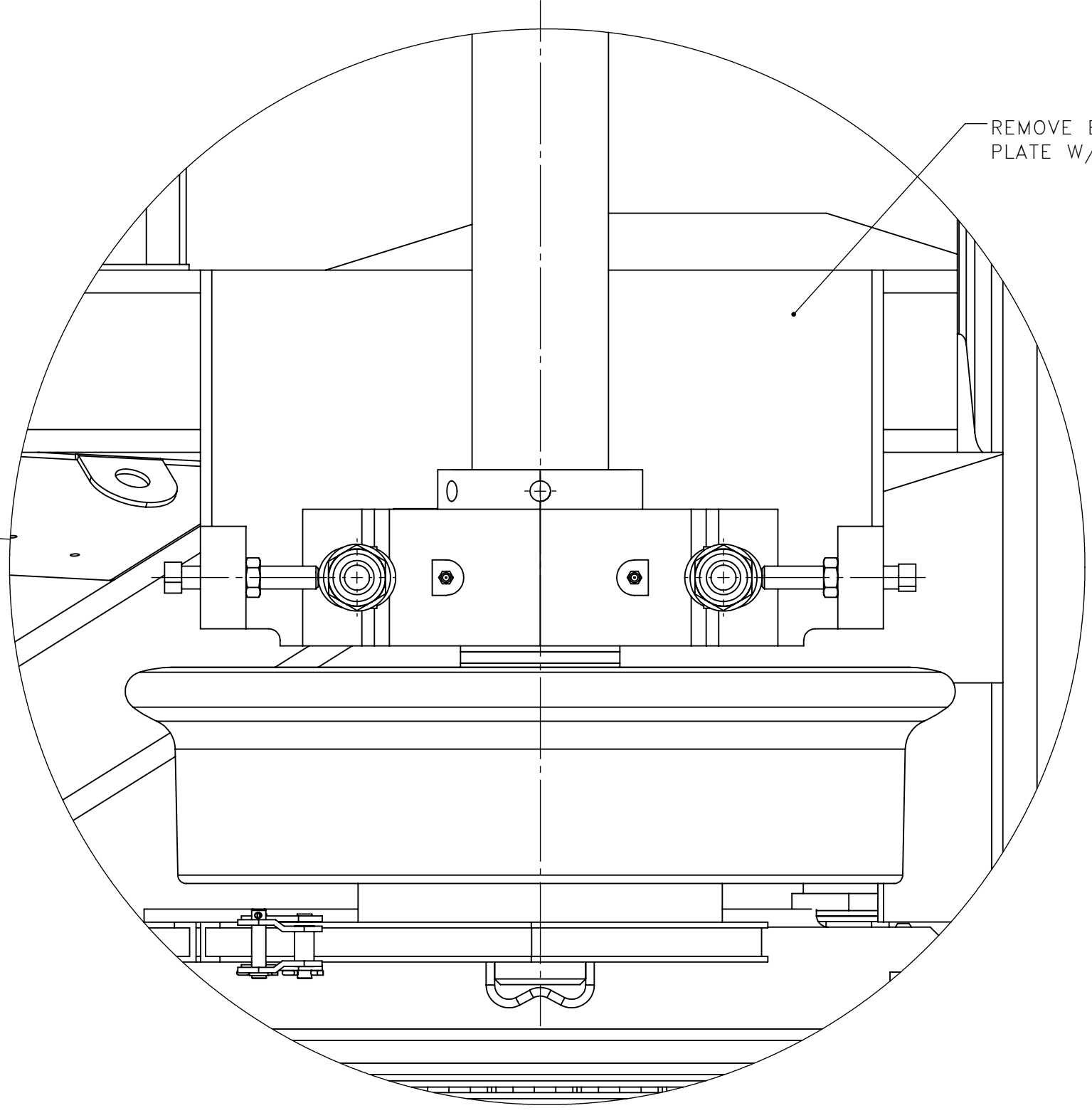

SCALE 1 : 3

REMOVE BEARING MOUNTING PLATE W/ LUGS

STEP 2 - AXLE BEARING MOUNTING PARTS REMOVAL

REV	EN	DESCRIPTION	DATE	DRN
1	00732	NEW RELEASE	7-24	ASM
DIMENSION TOLERANCES UNLESS OTHERWISE SPECIFIED				
LINEAR	.XX=±.03	.XXX=±.010	KERF ALLOW.	
ANGULAR	X°=±1°	X.X°=±.5°		
SURFACE FINISH		125	SMOOTH ALL SHARP EDGES	
NOT TO EXCEED			CLEAN ALL WELDS	
THIS PRINT AND ALL INFORMATION WITHIN BELONGS TO RACINE RAILROAD PRODUCTS				
RACINE RAILROAD PRODUCTS				
RACINE, WISCONSIN USA				
DESCRIPTION				
INSTRUCTIONS, 3.50 DIA AXLE KIT				
MATERIAL TYPE				
SEE BOM				
USED ON	935582	SCALE	DATE	
		1:20	07-16-24	
DRN	WEIGHT (LBS)	JOB NO	SHEET	
ASM	17523.99	RD190005	2 OF 5	
DWG SIZE	CATALOG	DWG NO		
D	A			800422

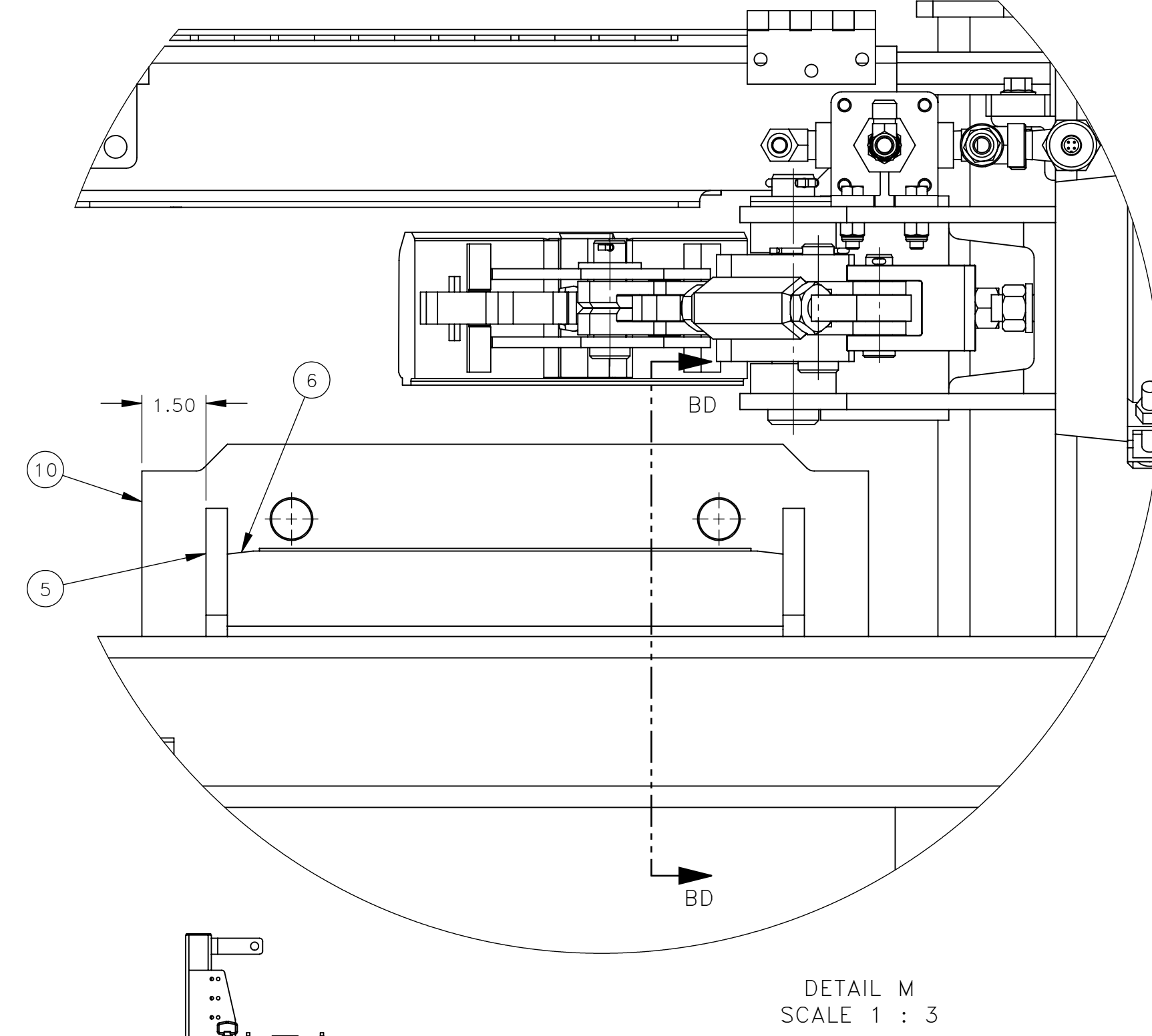
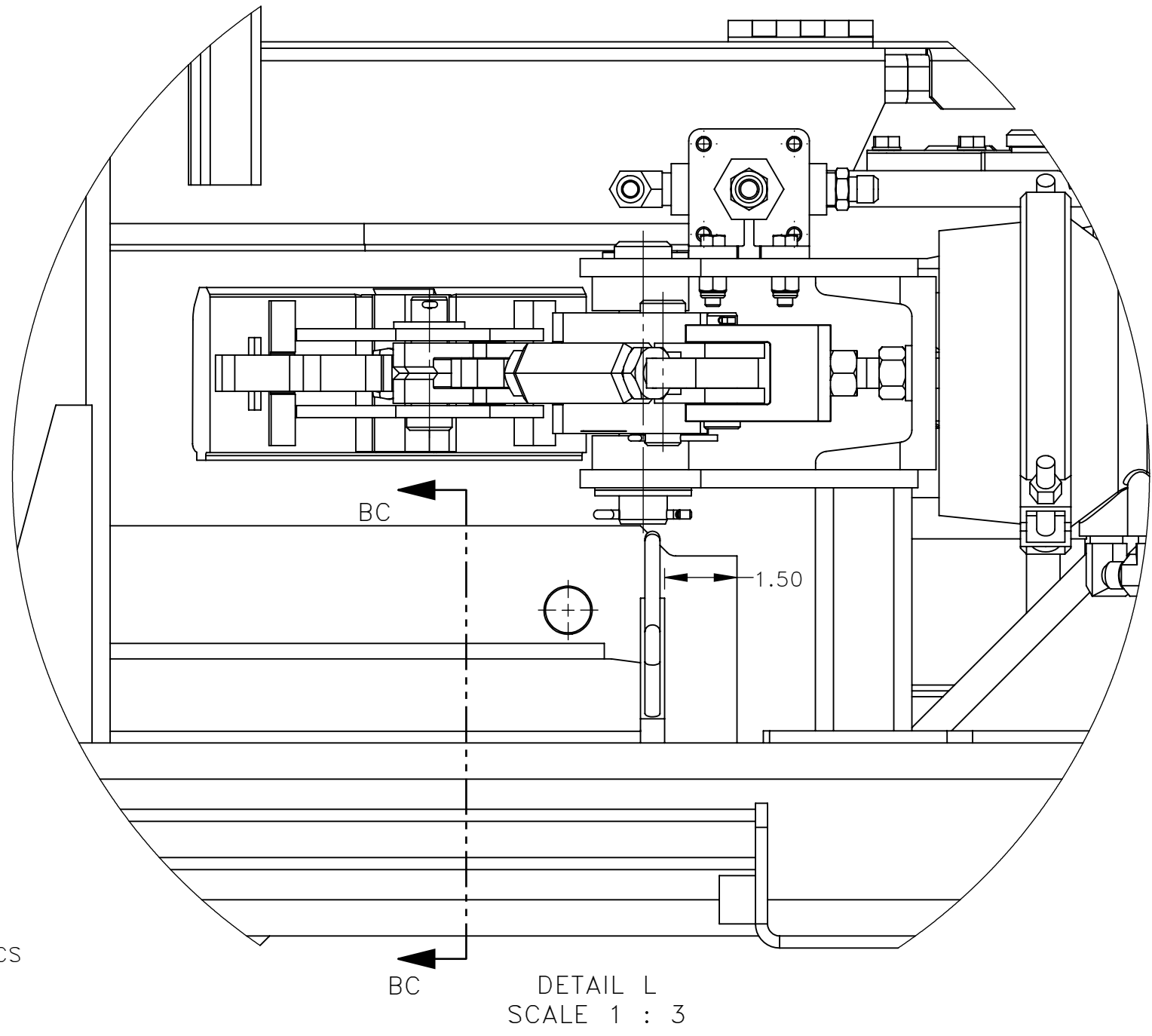
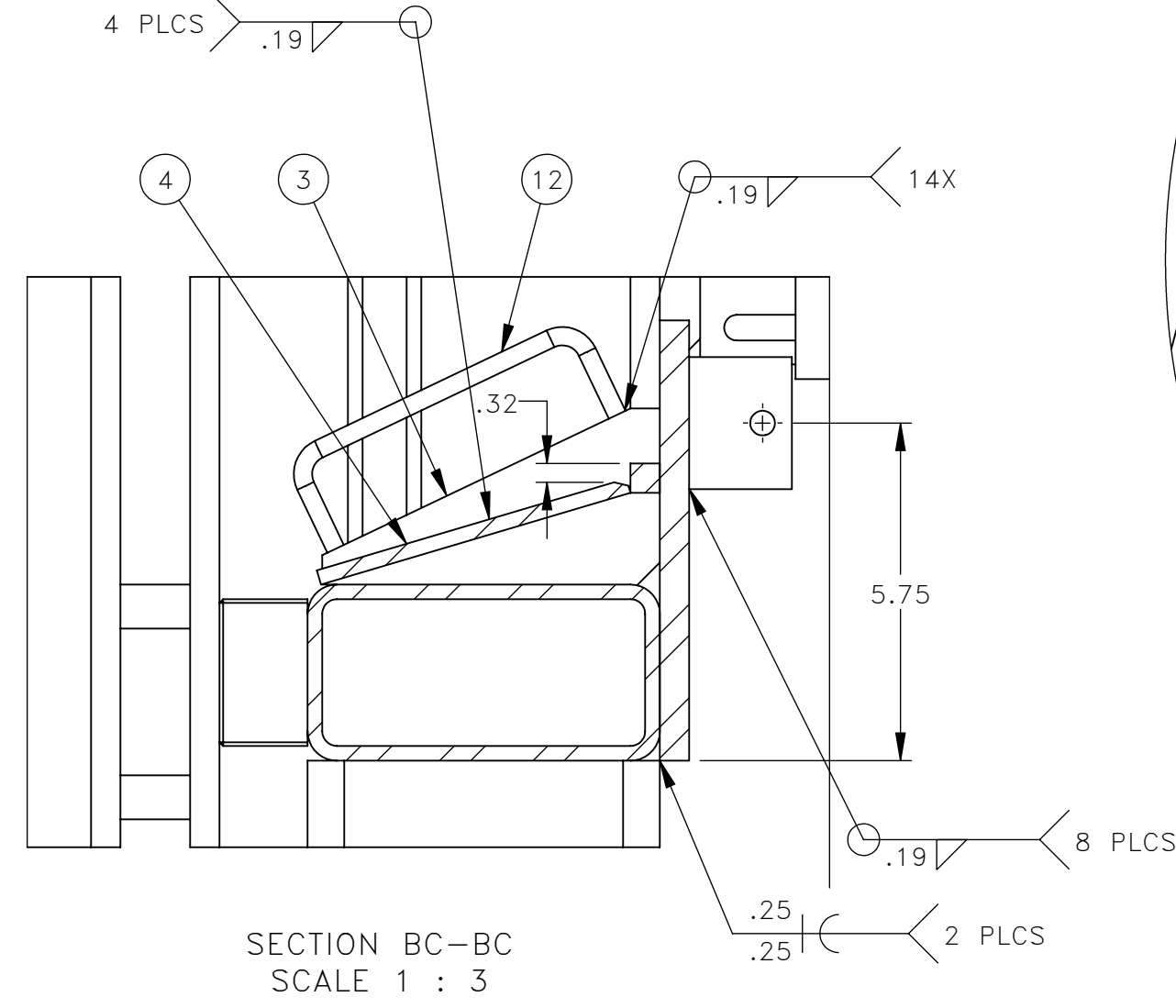

NO.	QTY	ADDED PARTS DESCRIPTION	PART NO.
1	REF	FLAT	319030
2	REF	LOOP, 5 W X 1.5 H	389064
3	REF	FLAT	398721
4	REF	FLAT	398722
5	REF	FLAT	399286
6	REF	FLAT	399287
7	REF	SCR, SQ SET: .5-13 X 3	405082
8	REF	NUT, HEX JAM: .5-13	491298
9	REF	AXLE, 3.50 DIA INS #80 28T	720655
10	REF	PLATE, BEARING	782557
11	REF	PLATE, BEARING	782559
12	REF	PLATE, BEARING	782562

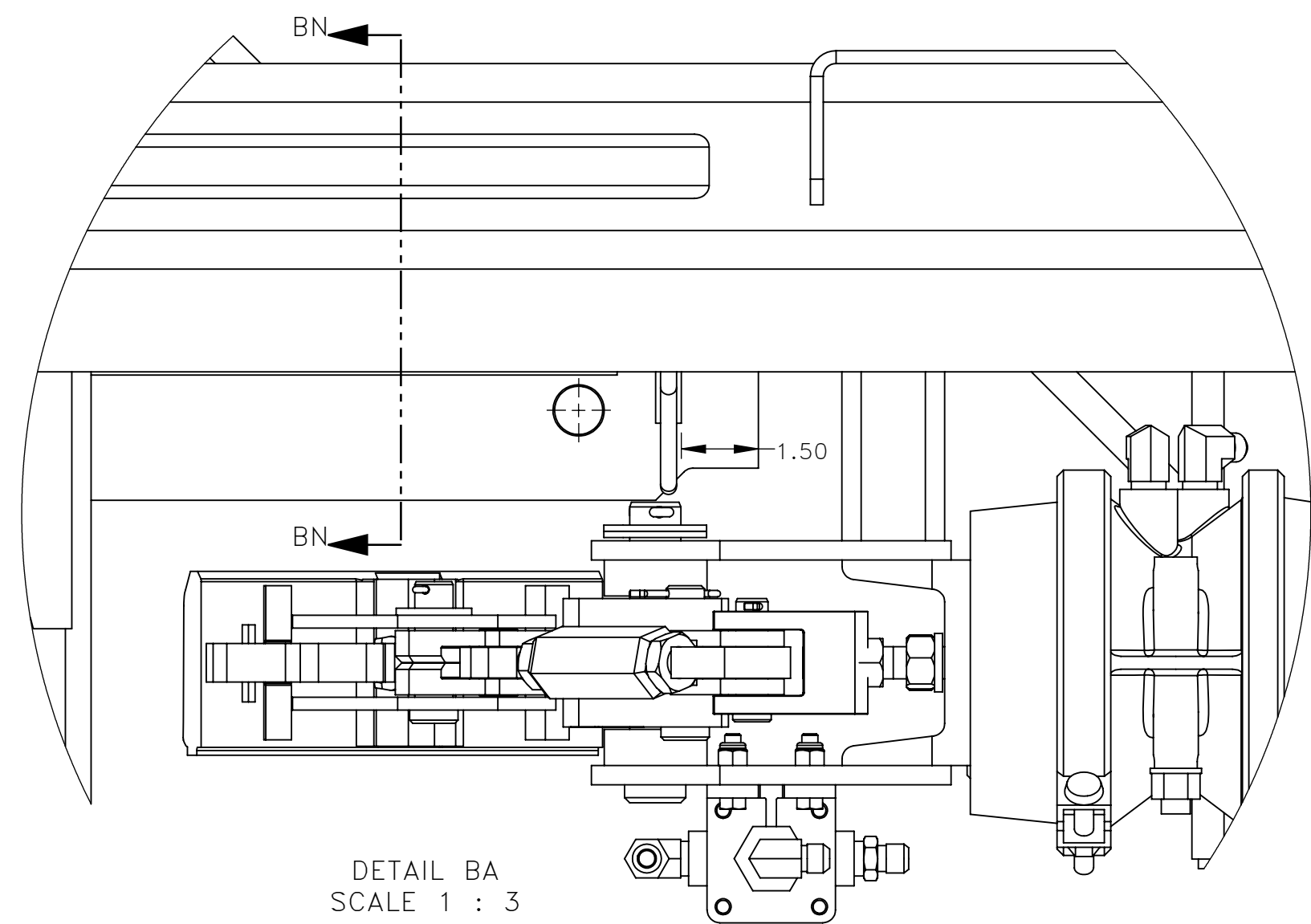
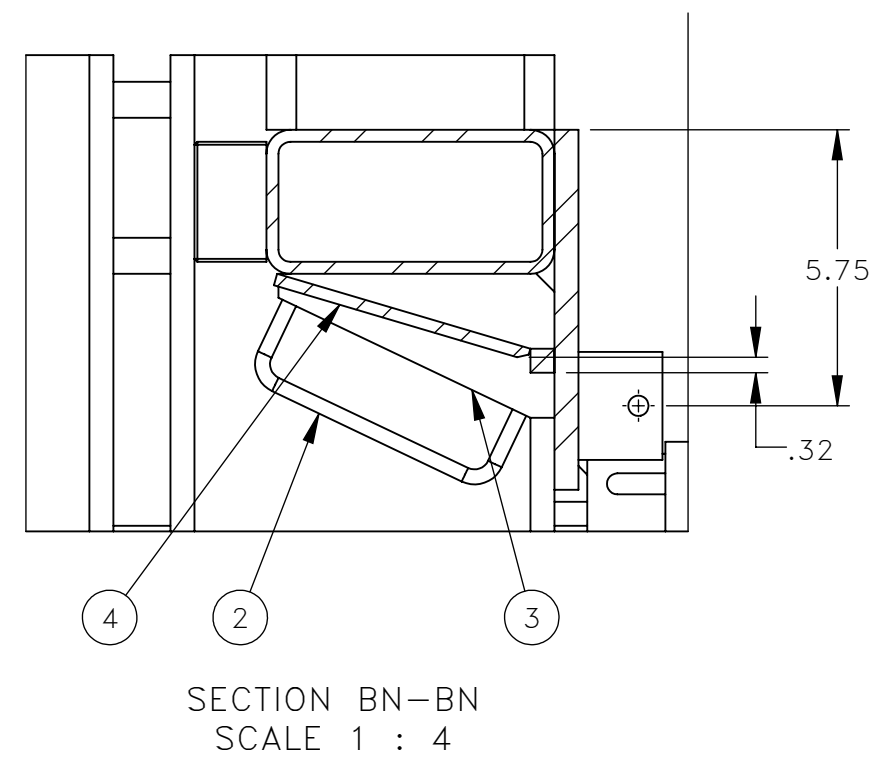
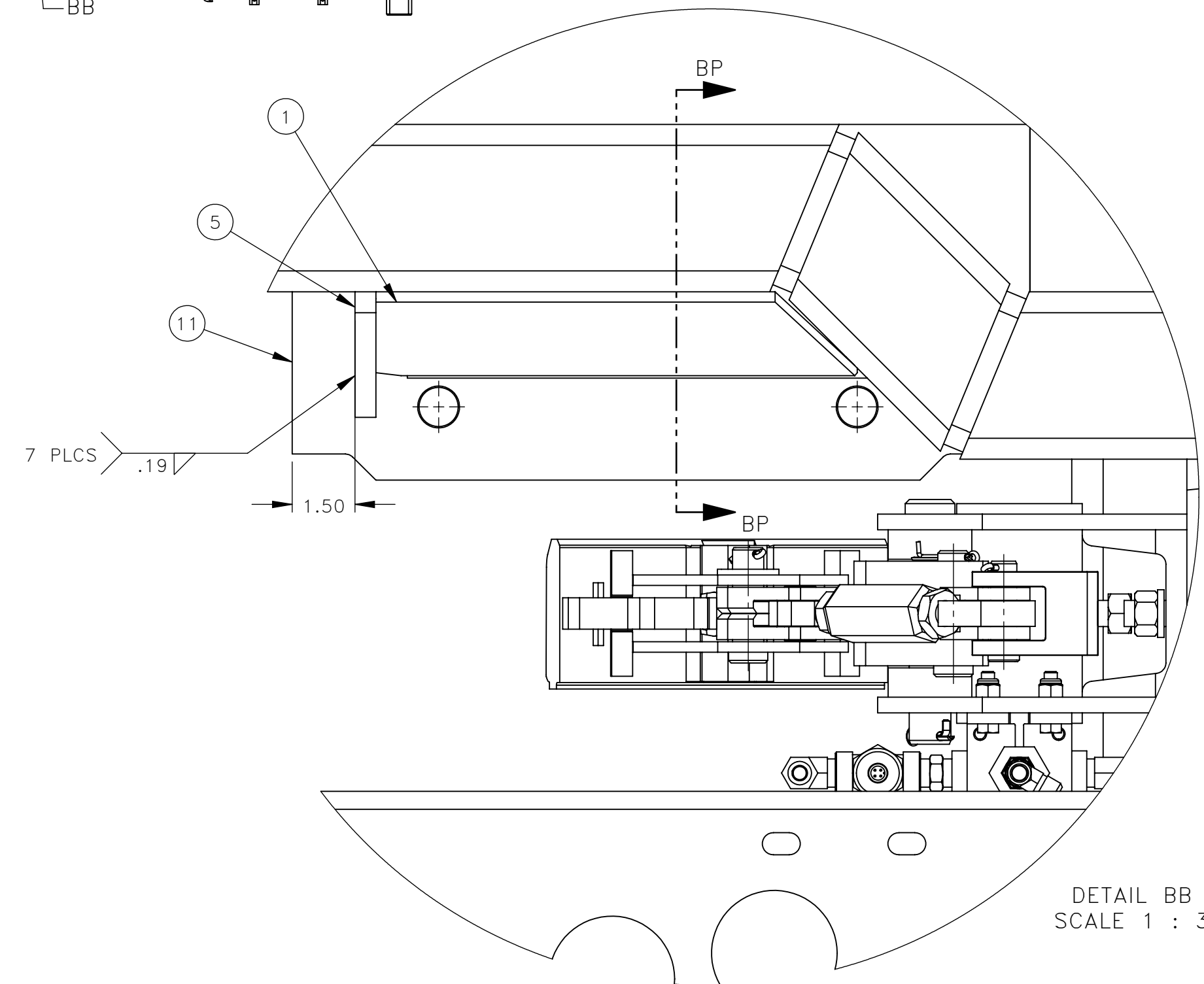
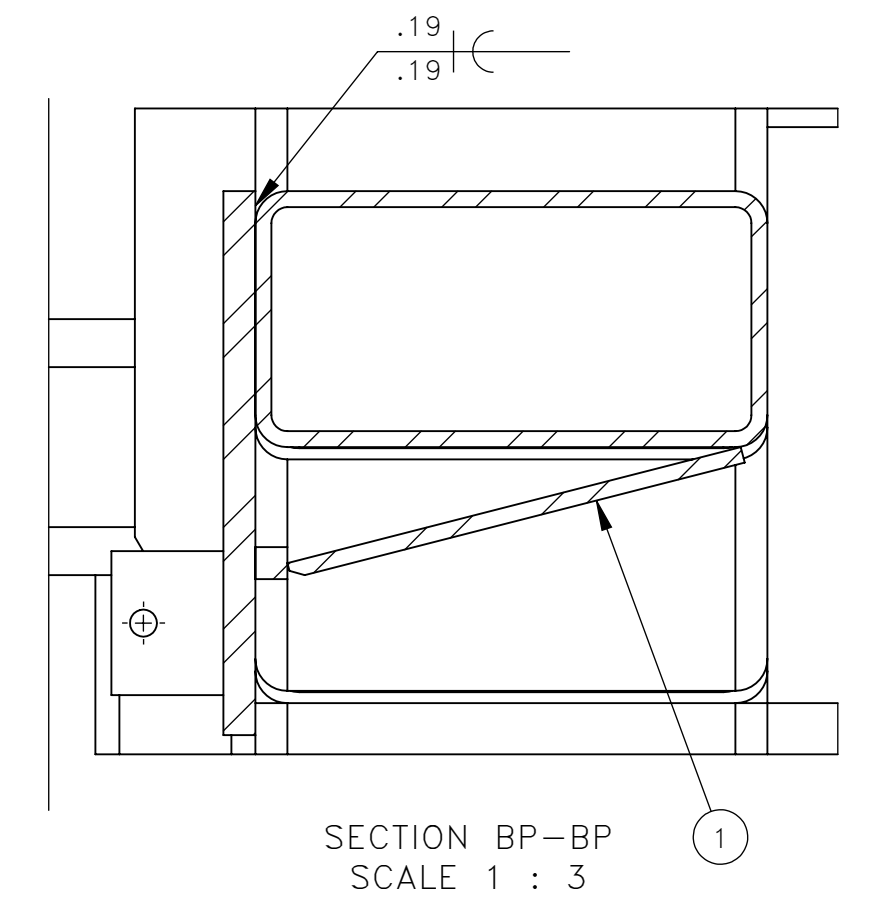
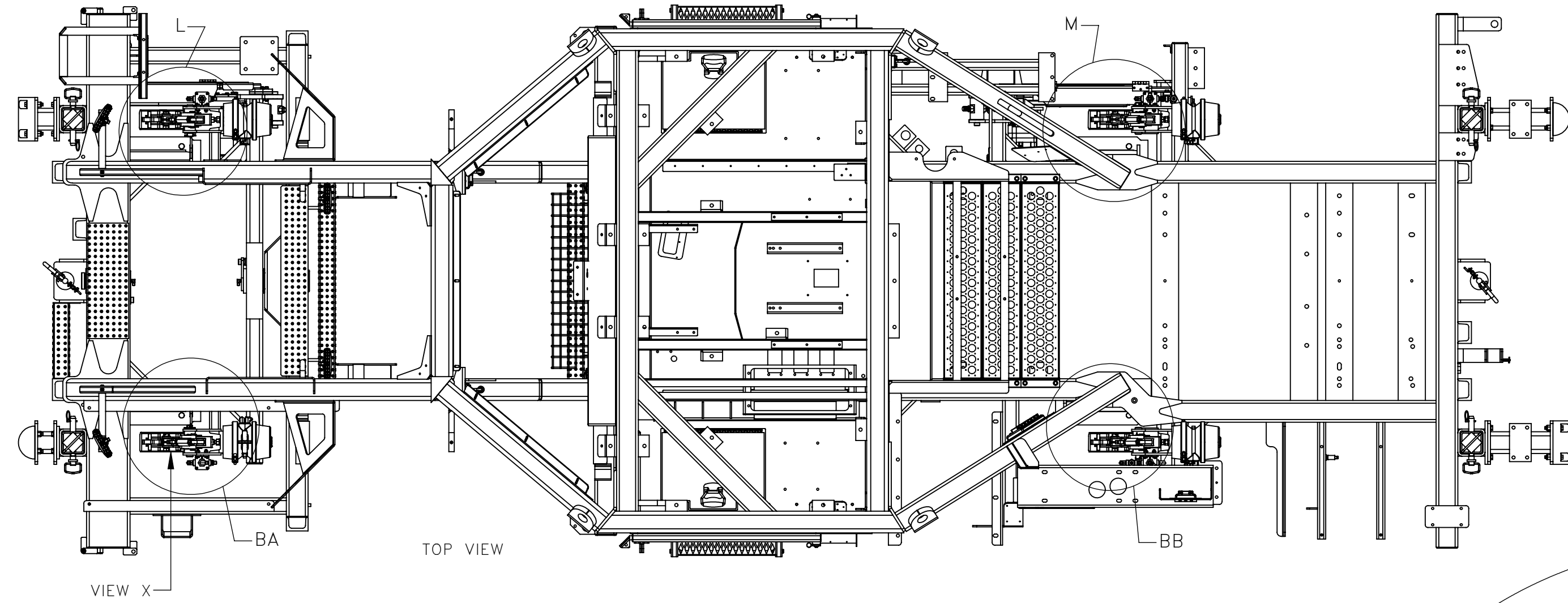
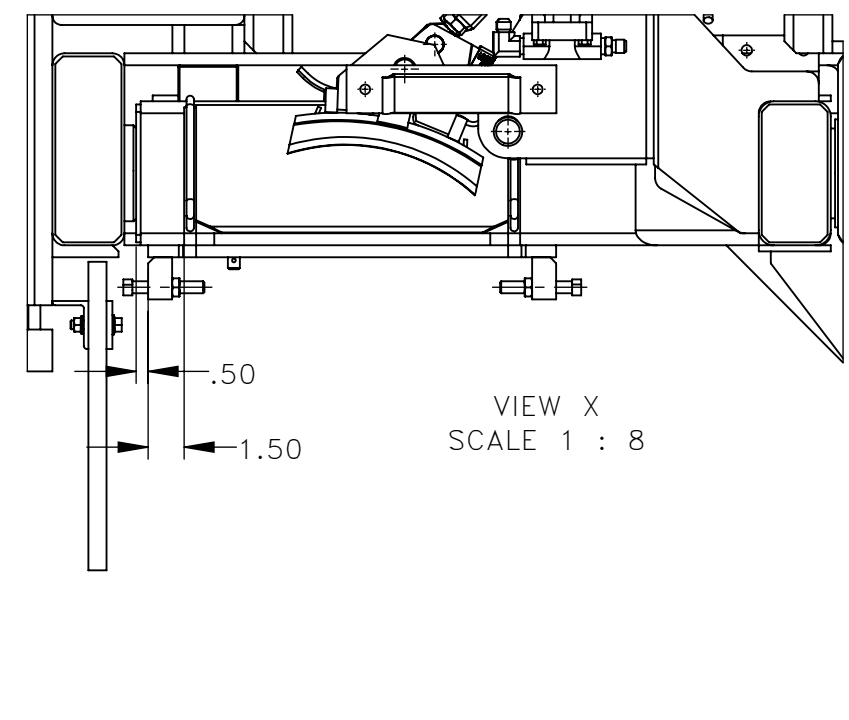
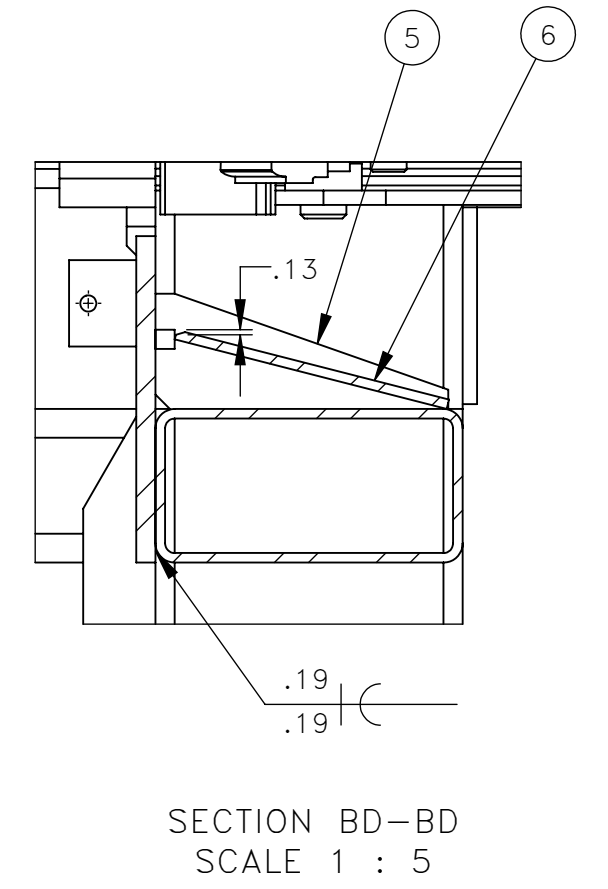

REV	EN	DESCRIPTION	DATE	DRN
1	00732	NEW RELEASE	7-24	ASM

DIMENSION TOLERANCES UNLESS OTHERWISE SPECIFIED

LINEAR	.XX=±.03	.XXX=±.010	KERF ALLOW.
ANGULAR	X'=±1°	X.X'=±.5°	

SURFACE FINISH 125 ✓ SMOOTH ALL SHARP EDGES
NOT TO EXCEED CLEAN ALL WELDS

THIS PRINT AND ALL INFORMATION WITHIN BELONGS TO RACINE RAILROAD PRODUCTS

RACINE RAILROAD PRODUCTS
RACINE, WISCONSIN USA

DESCRIPTION: CHASSIS

MATERIAL TYPE: SEE BOM

USED ON	935582	SCALE	DATE
		1:20	07-16-24
DRN	17728.65	JOB NO	SHEET
ASM		RD190005	3 OF 5
DWG SIZE	D	CATALOG	DWG NO
		A	800422

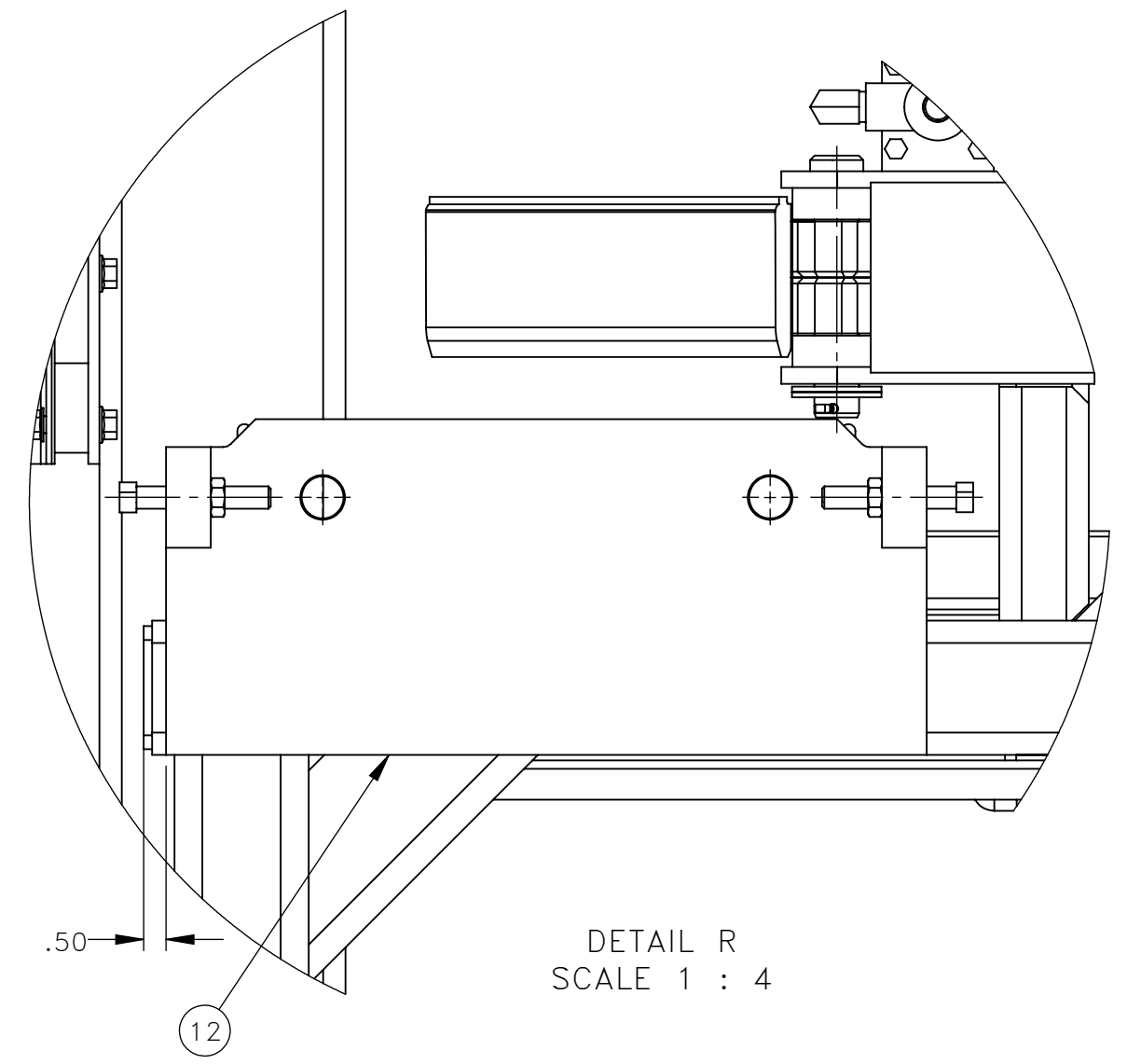

DETAIL R
SCALE 1 : 4

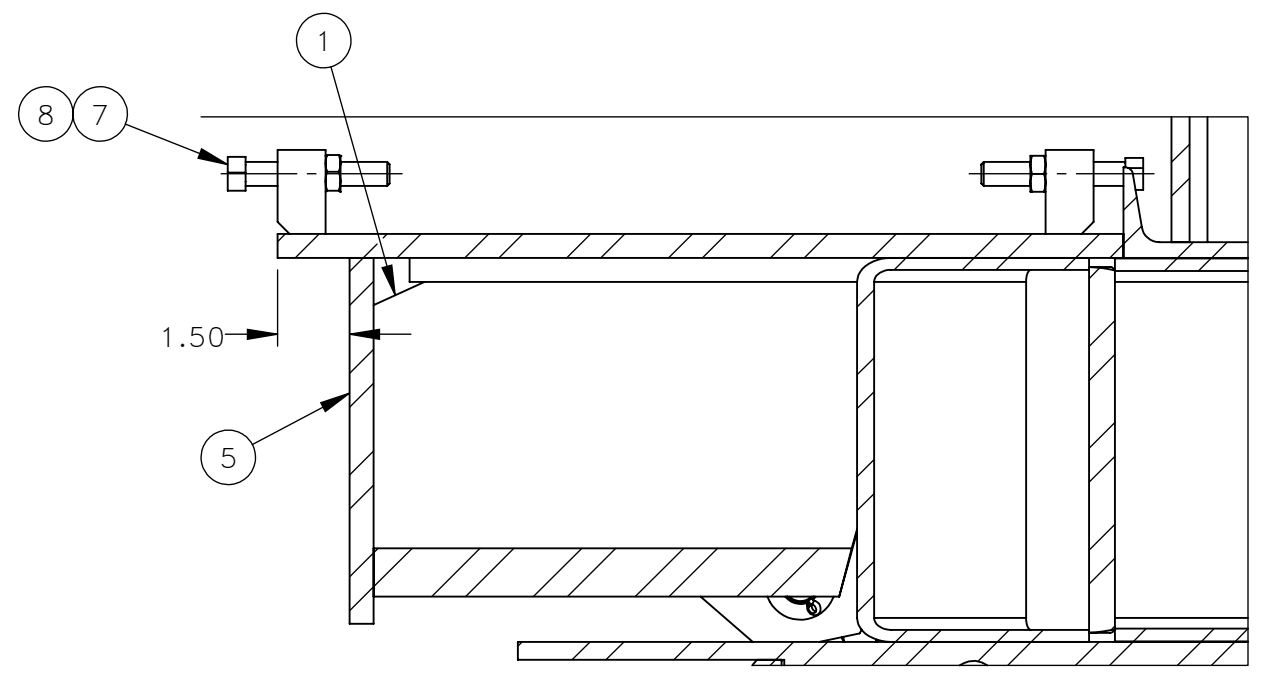

SECTION BJ-BJ
SCALE 1 : 4

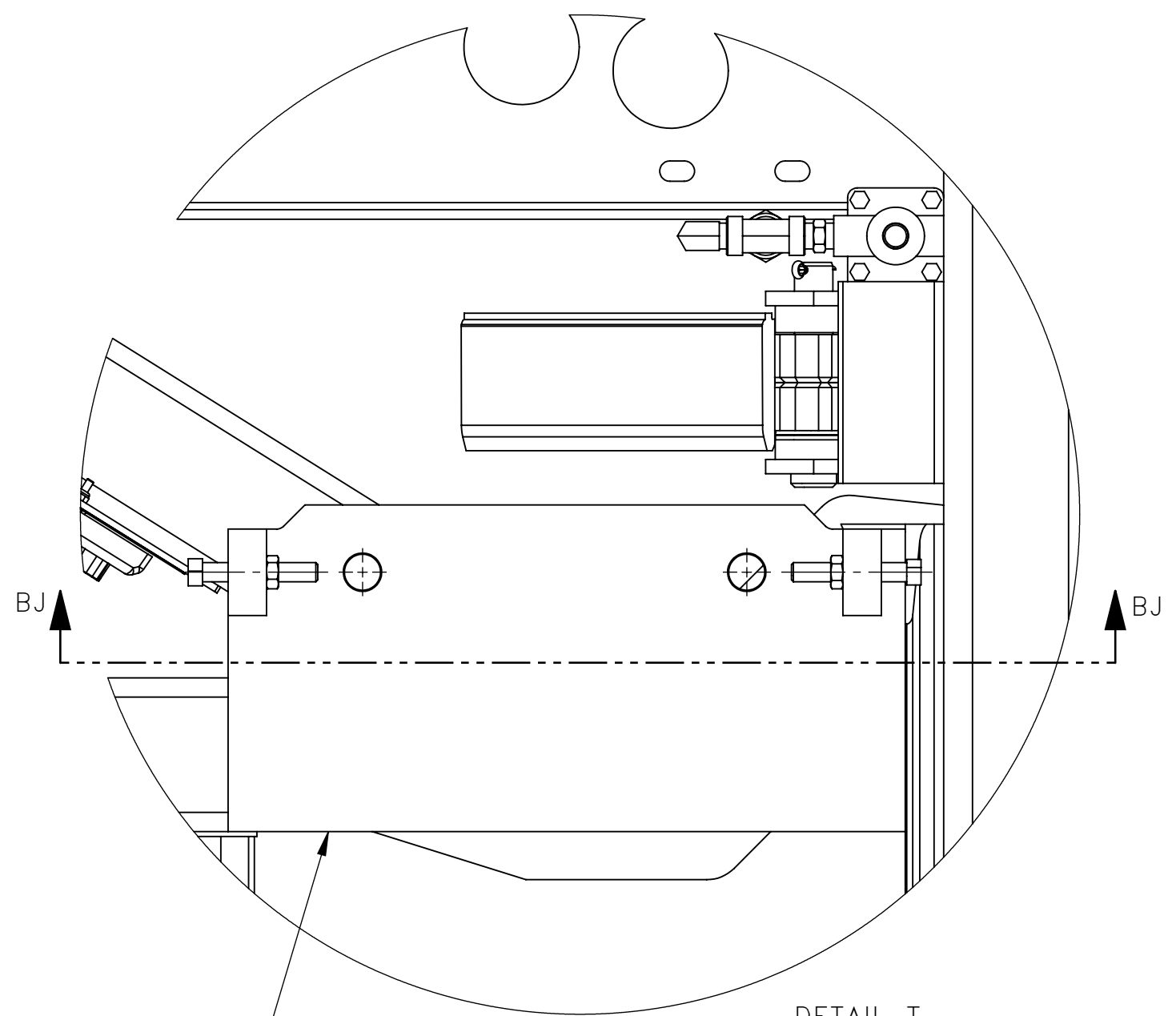

DETAIL T
SCALE 1 : 4

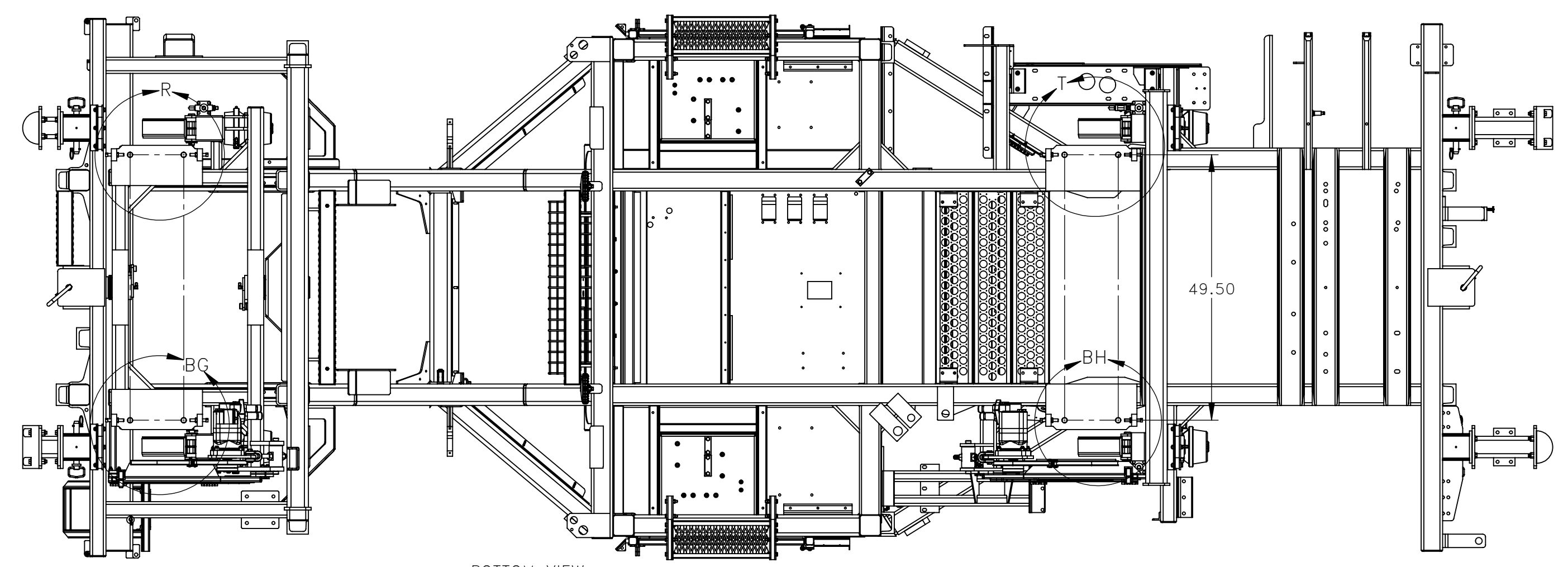

BOTTOM VIEW

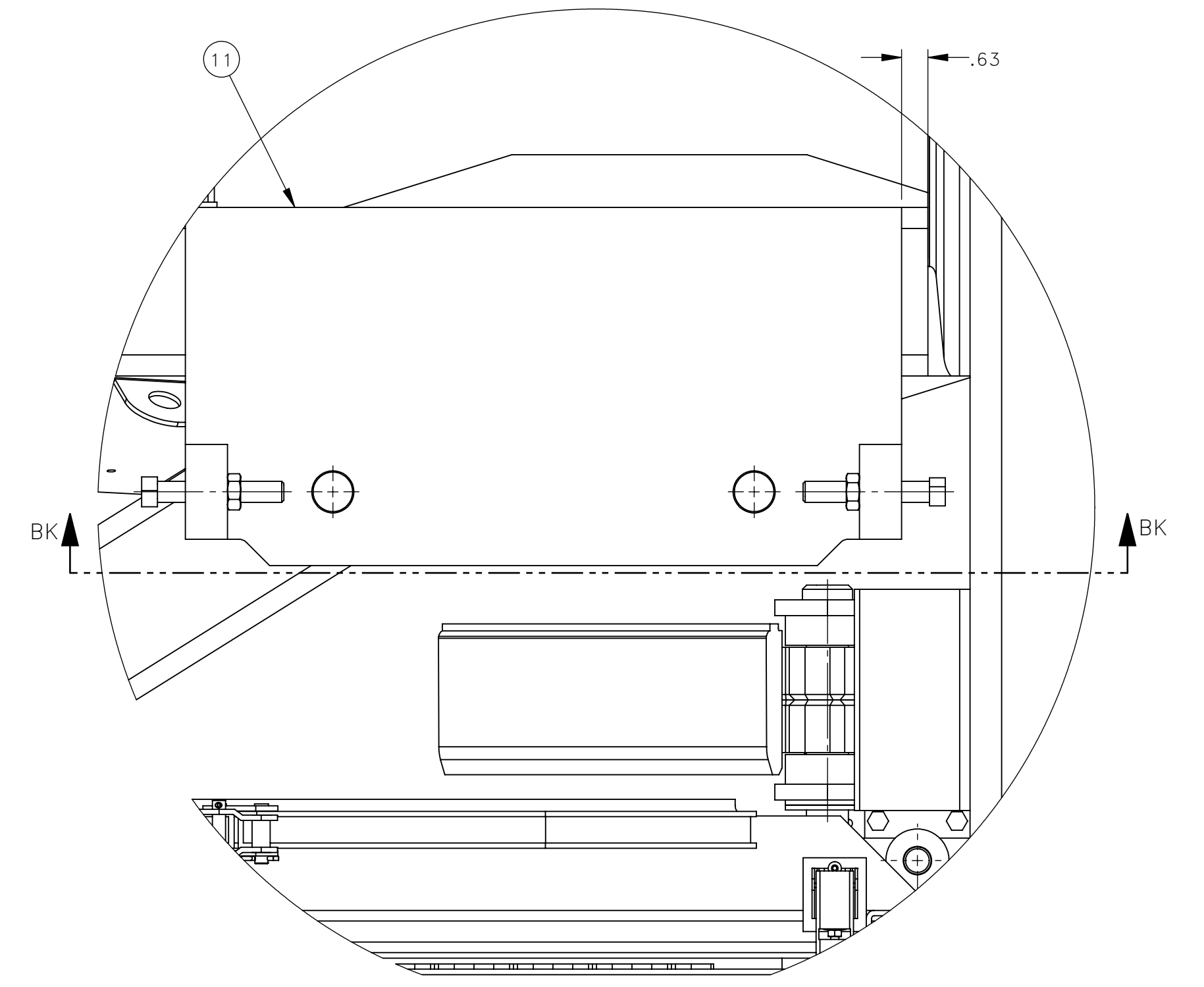

DETAIL BH
SCALE 1 : 3

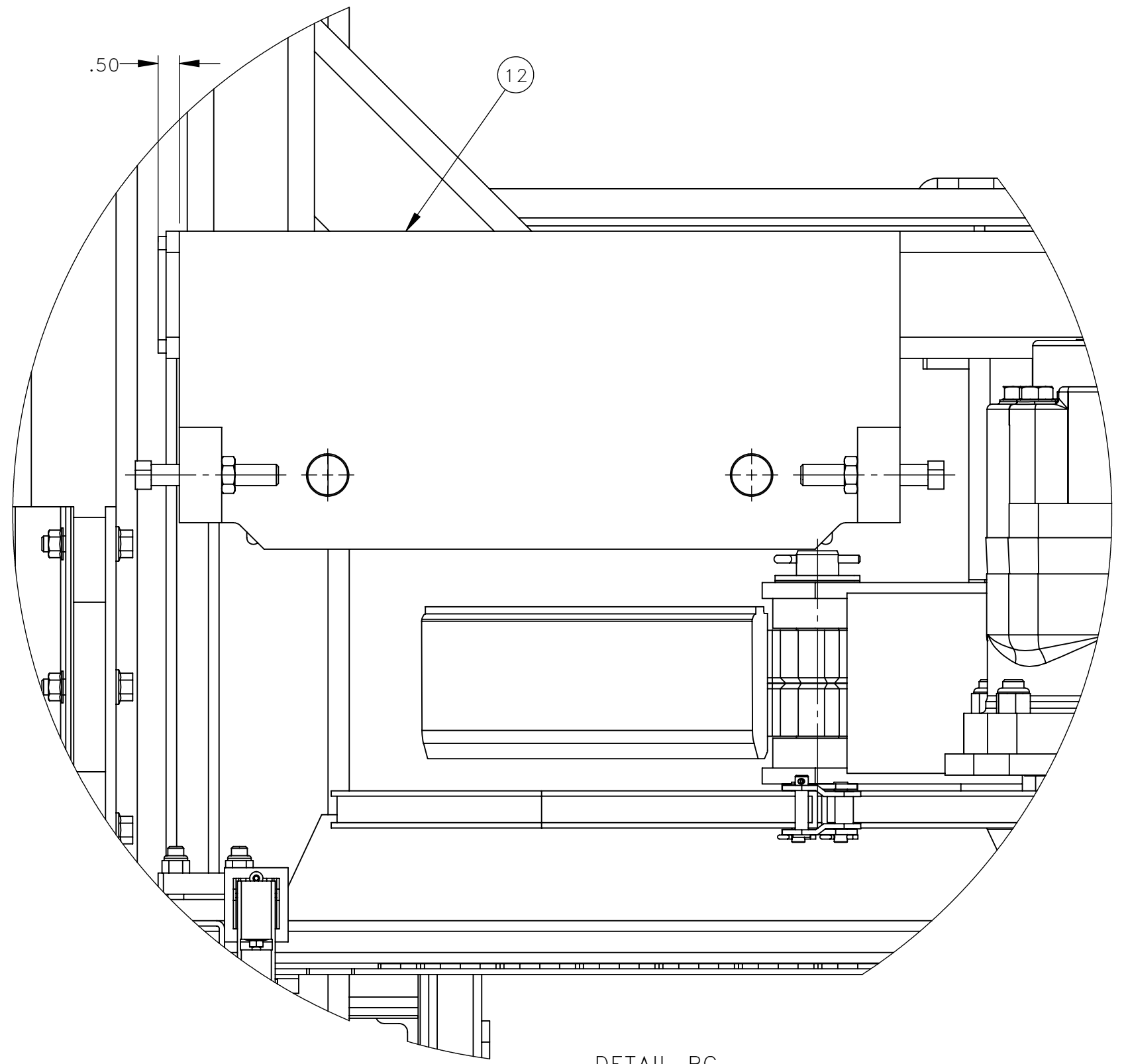

DETAIL BG
SCALE 1 : 3

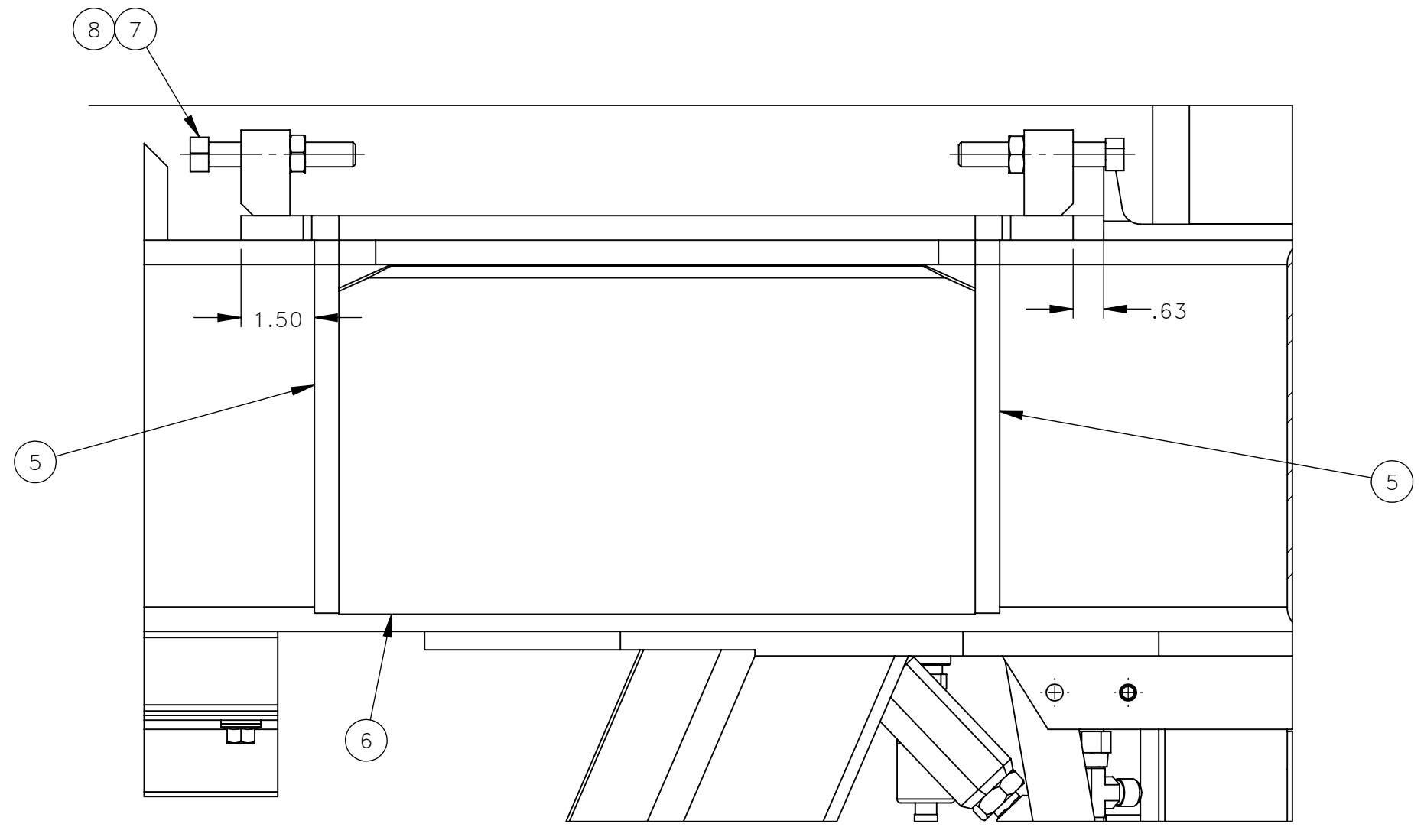

SECTION BK-BK
SCALE 1 : 3

REV	EN	DESCRIPTION	DATE	DRN
1	00732	NEW RELEASE	7-24	ASM
DIMENSION TOLERANCES UNLESS OTHERWISE SPECIFIED				
LINEAR	.XX=±.03	.XXX=±.010	KERF ALLOW.	
ANGULAR	X°=±1°	X.X°=±.5°		
SURFACE FINISH		125	SMOOTH ALL SHARP EDGES	
NOT TO EXCEED			CLEAN ALL WELDS	
THIS PRINT AND ALL INFORMATION WITHIN BELONGS TO RACINE RAILROAD PRODUCTS				
RACINE RAILROAD PRODUCTS				
RACINE, WISCONSIN USA				
DESCRIPTION				
CHASSIS				
MATERIAL TYPE				
SEE BOM				
USED ON	935582	SCALE	DATE	
		1:20	07-16-24	
DRN	WEIGHT (LBS)	JOB NO	SHEET	
ASM	17728.65	RD190005	4 OF 5	
DWG SIZE	CATALOG	DWG NO		
D	A			800422

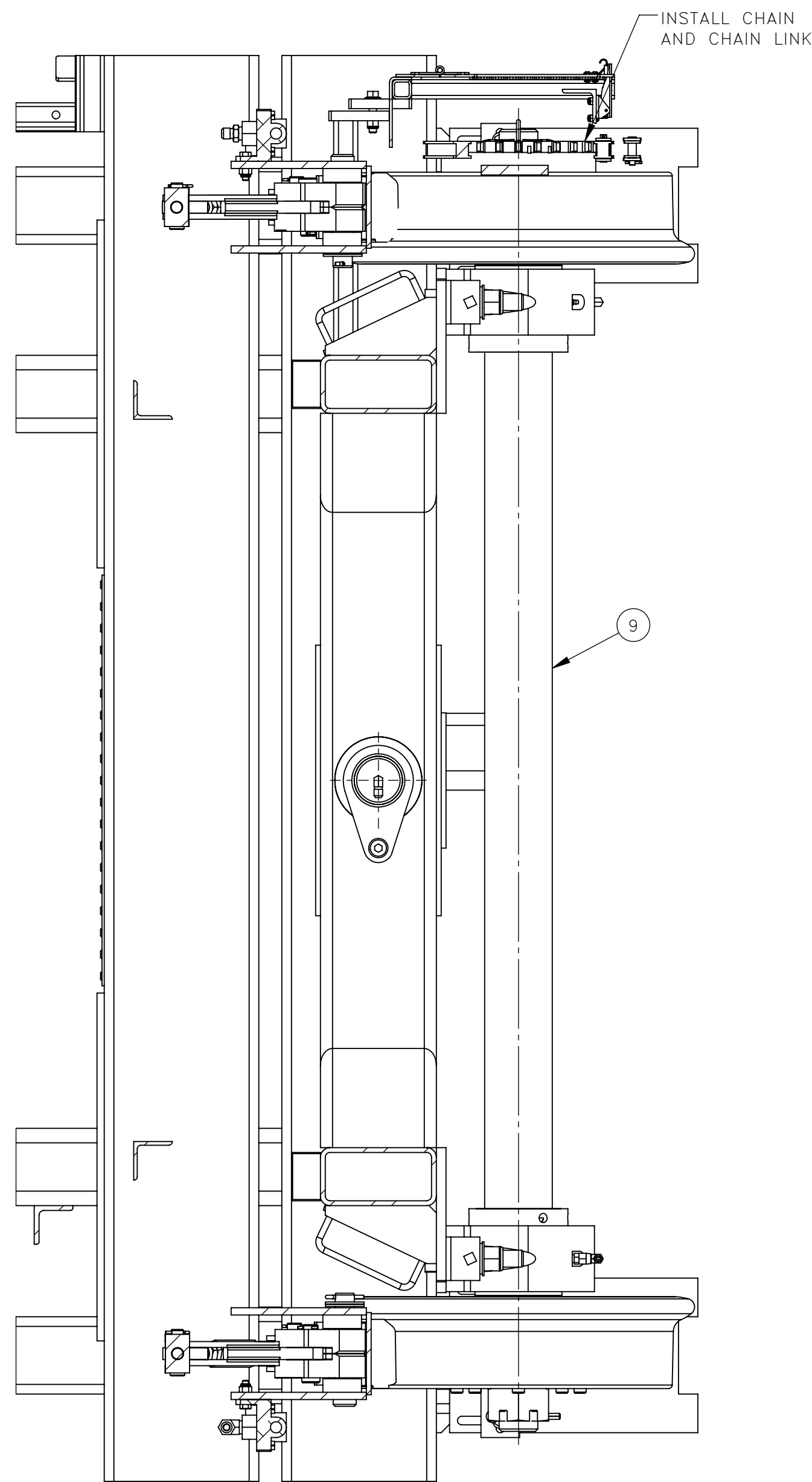

SECTION B-B
SCALE 1 : 6

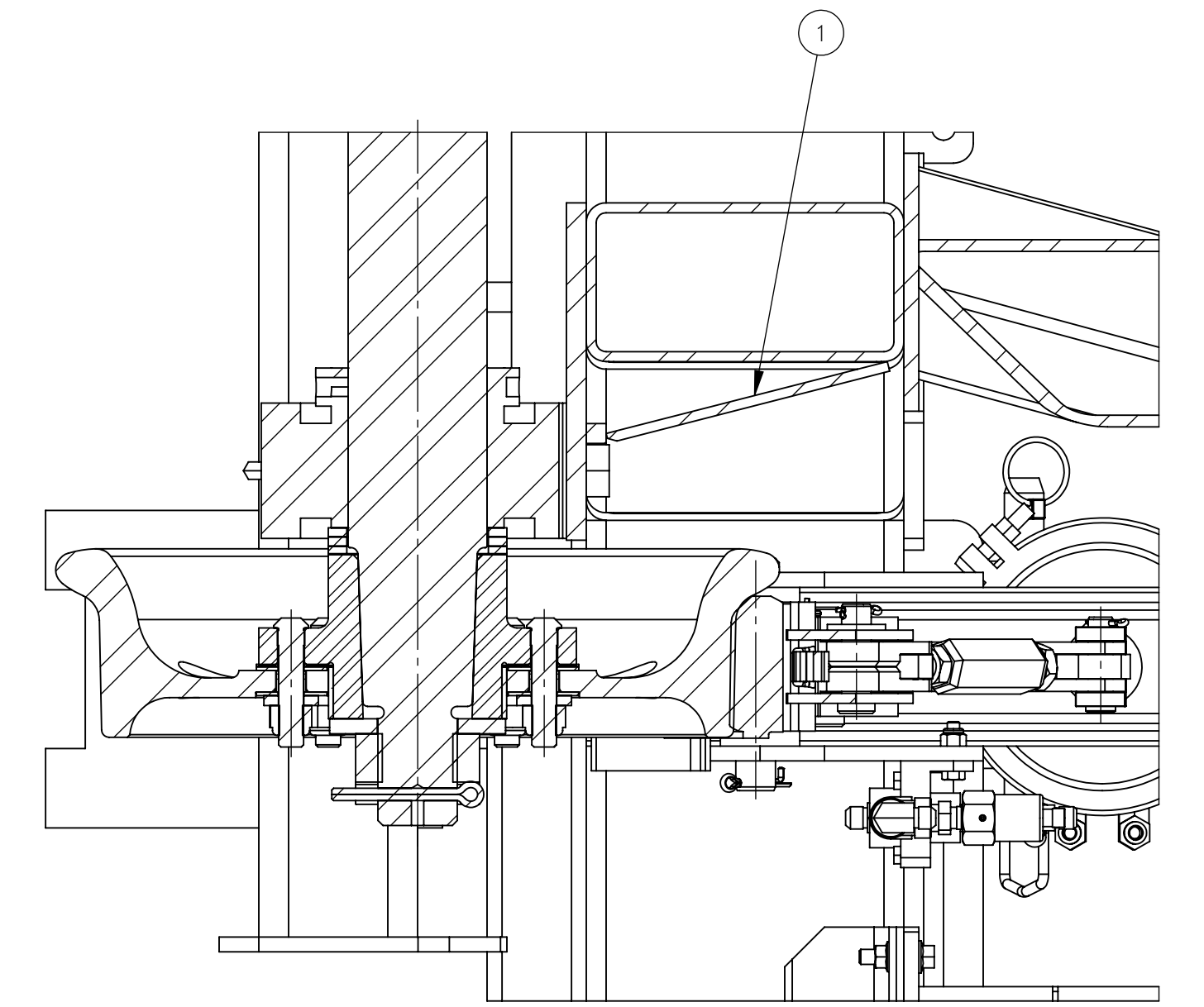
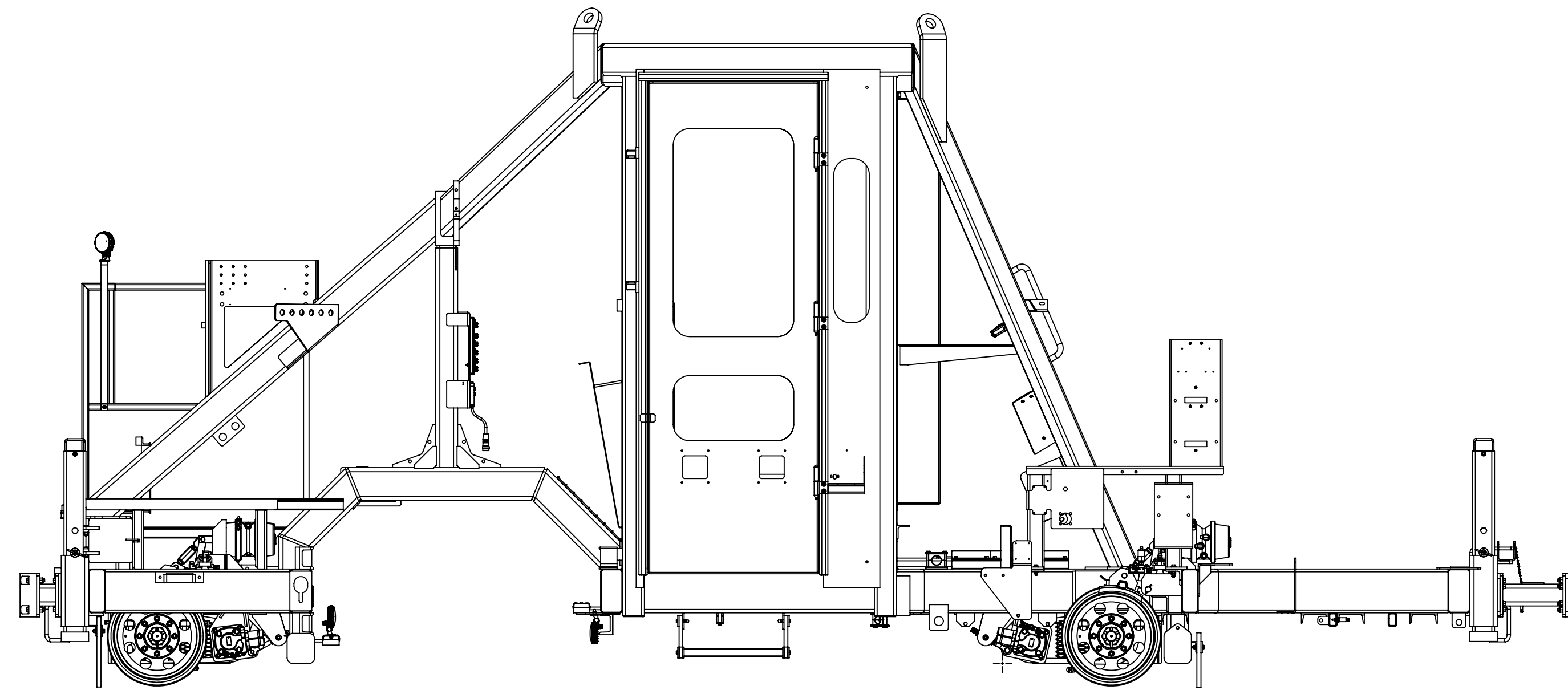
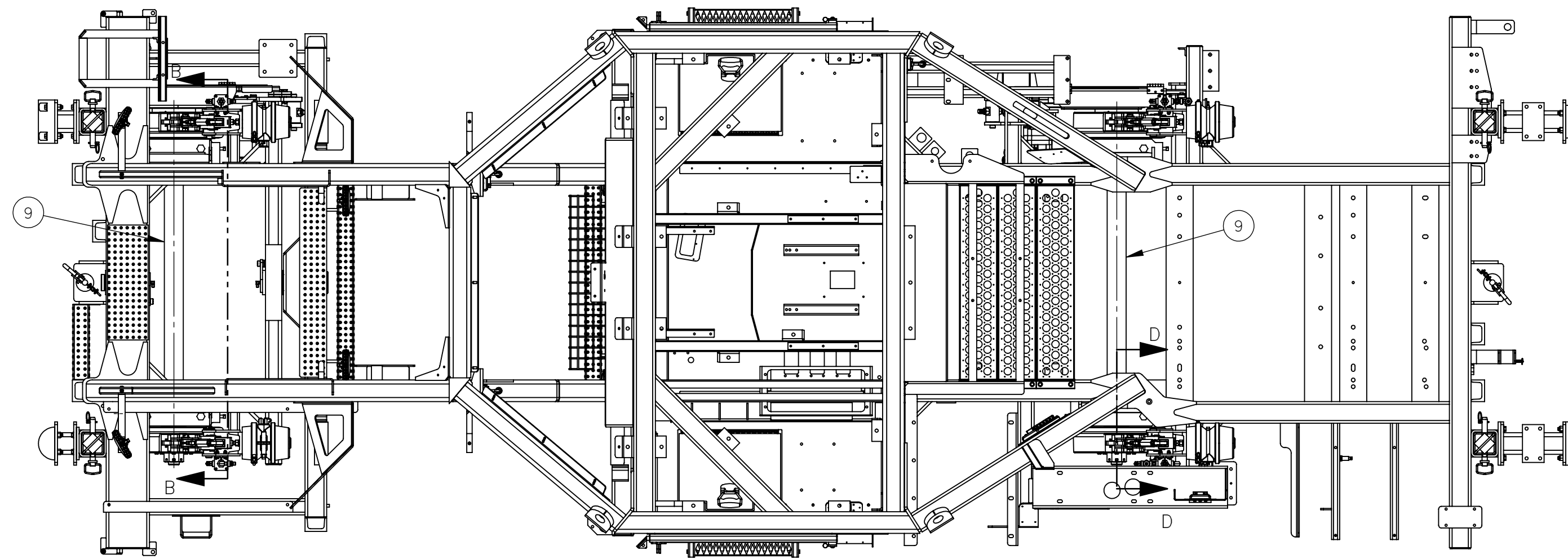

SECTION D-D
SCALE 1 : 4

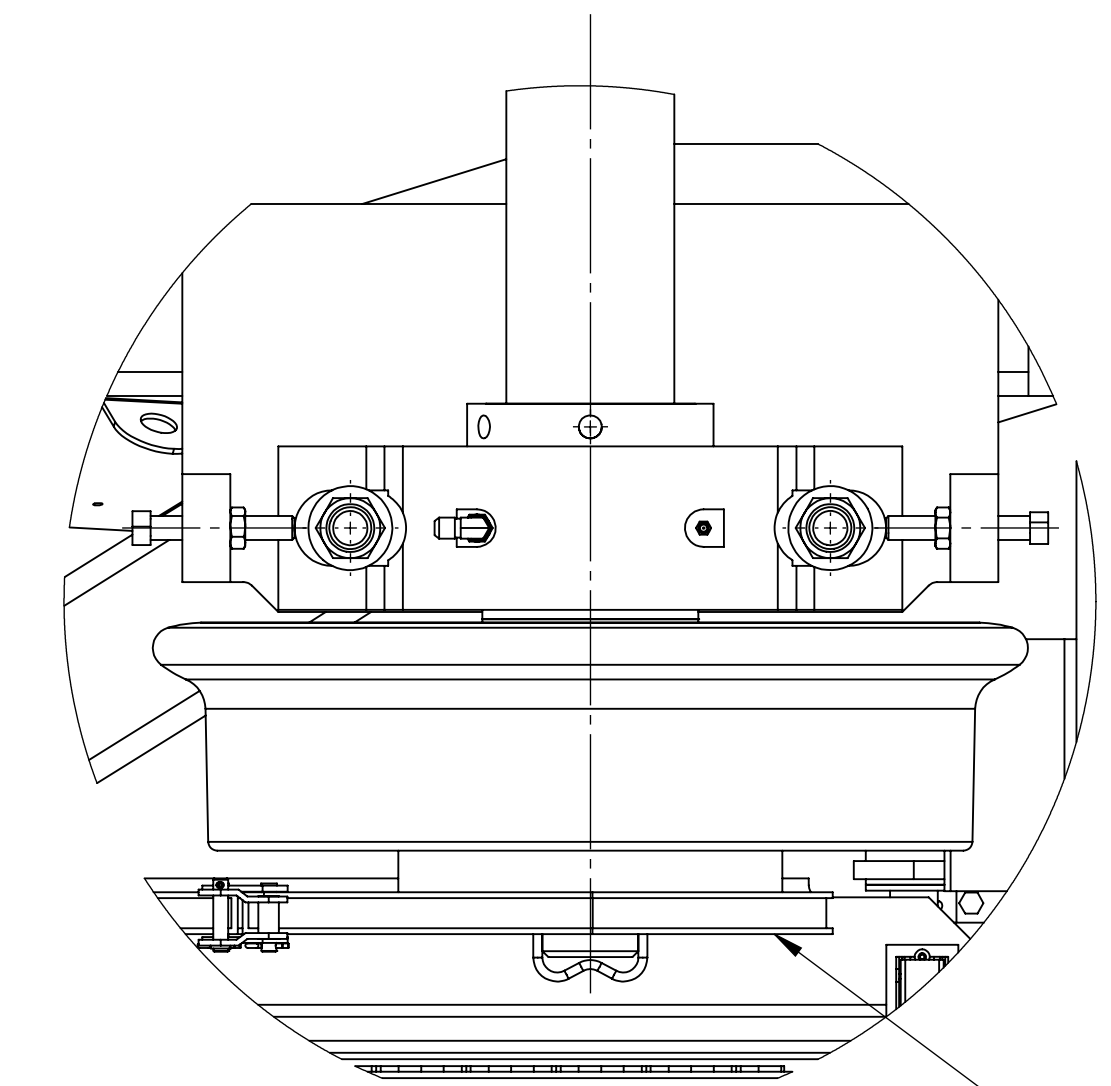

DETAIL AY
SCALE 1 : 4

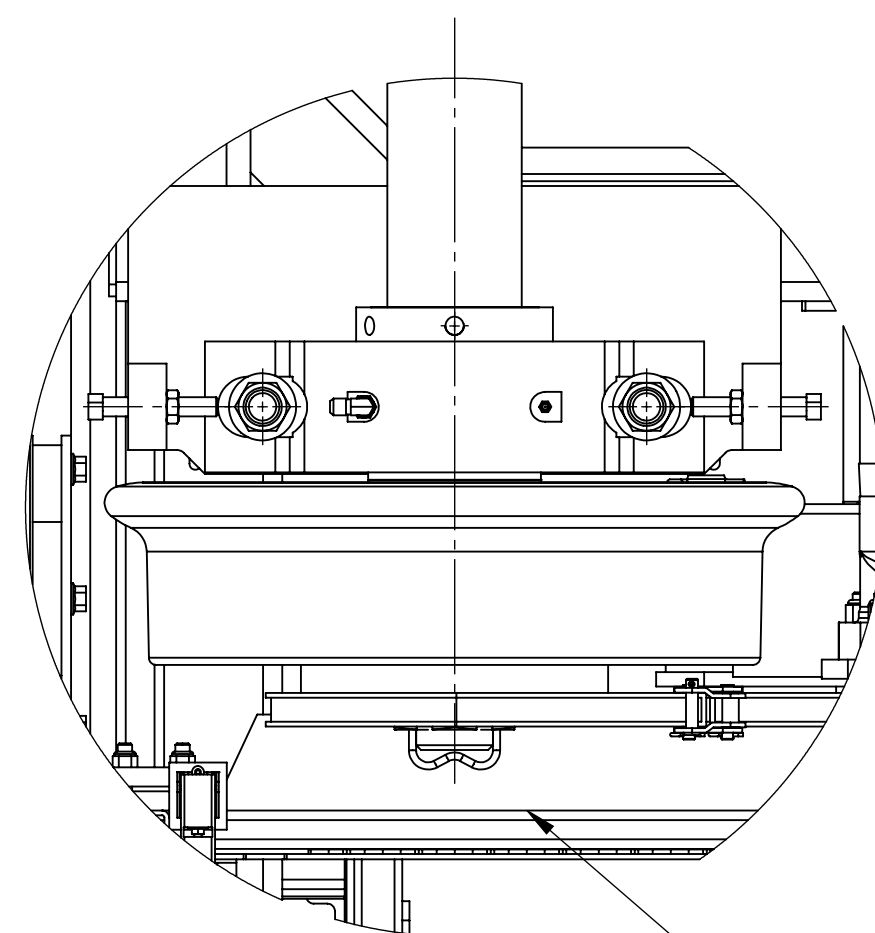

DETAIL V
SCALE 1 : 5

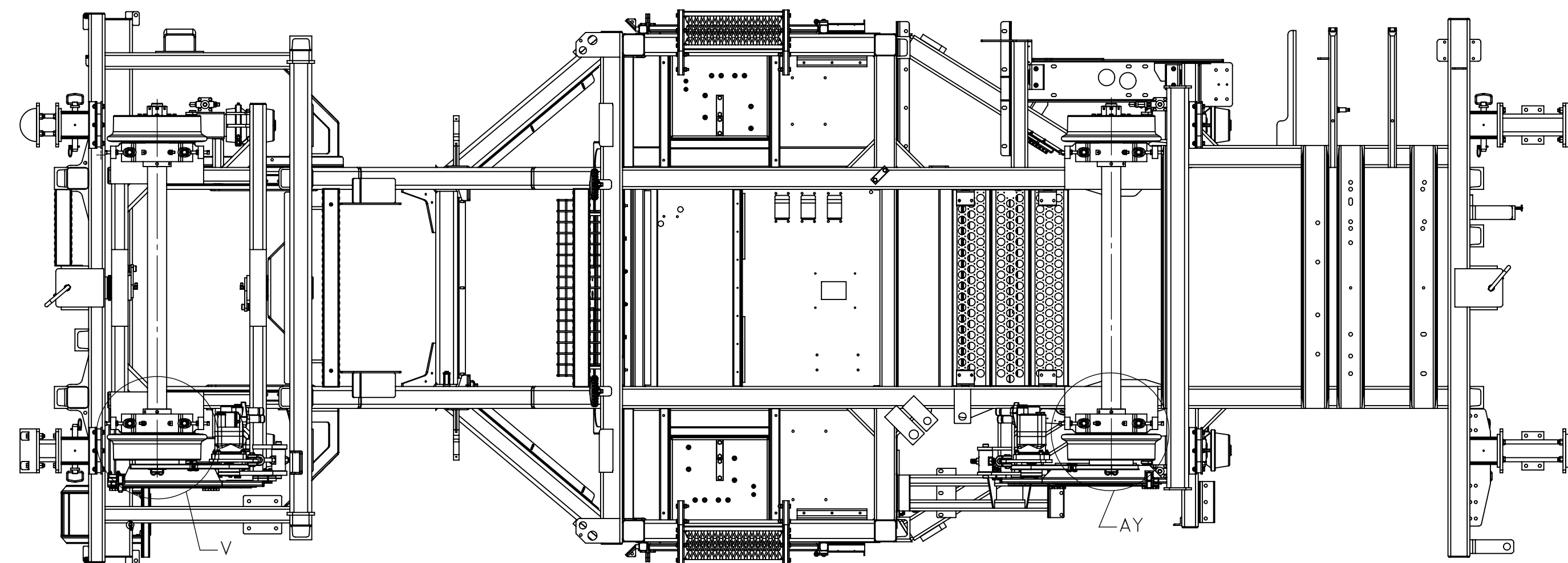

REV	EN	DESCRIPTION	DATE	DRN
1		00732 NEW RELEASE	7-24	ASM
DIMENSION TOLERANCES UNLESS OTHERWISE SPECIFIED				
LINEAR		.XX=±.03	.XXX=±.010	KERF ALLOW.
ANGULAR		X' = ±1"	X.X' = ±.5"	
SURFACE FINISH		125	SMOOTH ALL SHARP EDGES CLEAN ALL WELDS	
THIS PRINT AND ALL INFORMATION WITHIN BELONGS TO RACINE RAILROAD PRODUCTS				
RACINE RAILROAD PRODUCTS RACINE, WISCONSIN USA				
DESCRIPTION CHASSIS				
MATERIAL TYPE SEE BOM				
USED ON		935582	SCALE	DATE
			1:20	07-16-24
DRN	WEIGHT (LBS)	JOB NO	SHEET	
ASM	17728.65	RD190005	5 OF 5	
DWG SIZE	CATALOG	DWG NO		
D	A		800422	