

5" RAIL-SQUEEZE/ADJUST

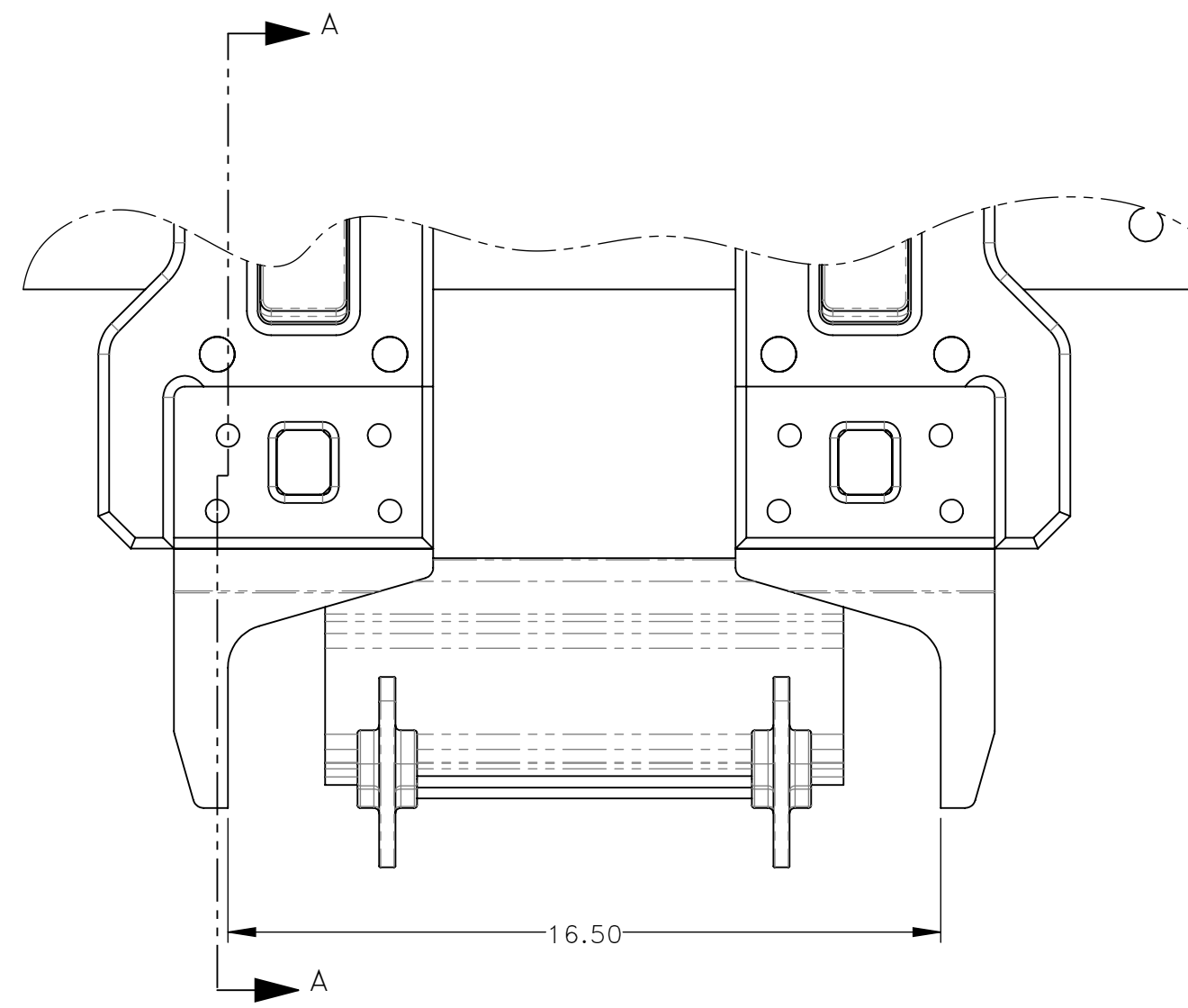

FOR GEN-5 COMBO MACHINES (9XX596):
SEE 720884 FOR DASP TOOL PARTS BOM

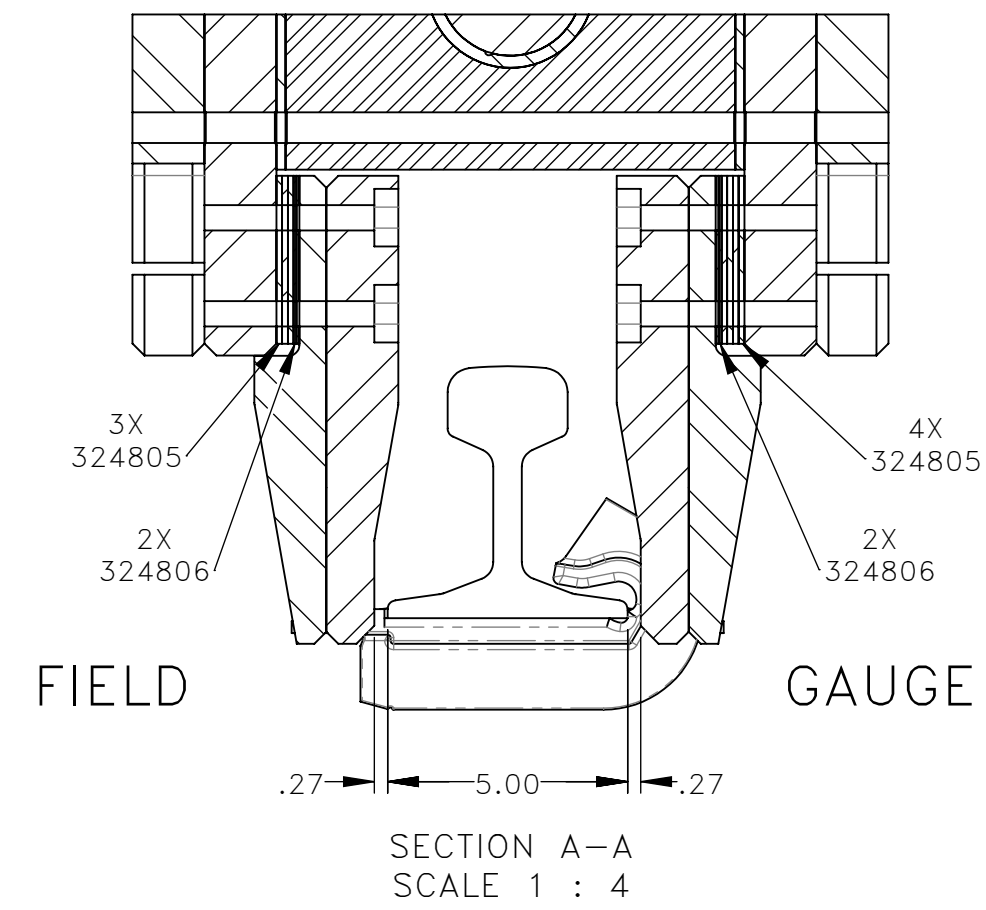
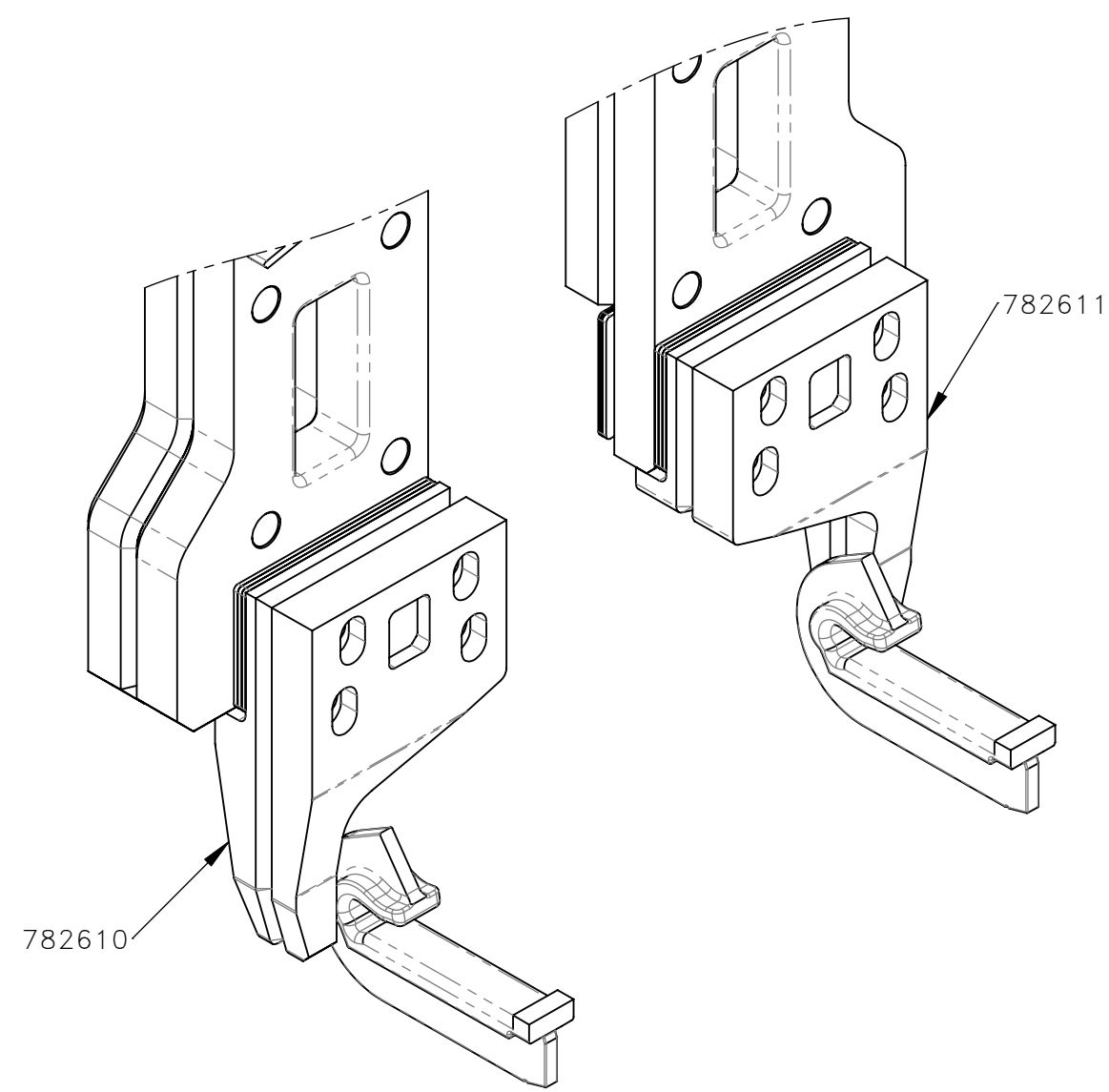

5.5" RAIL-SQUEEZE/ADJUST

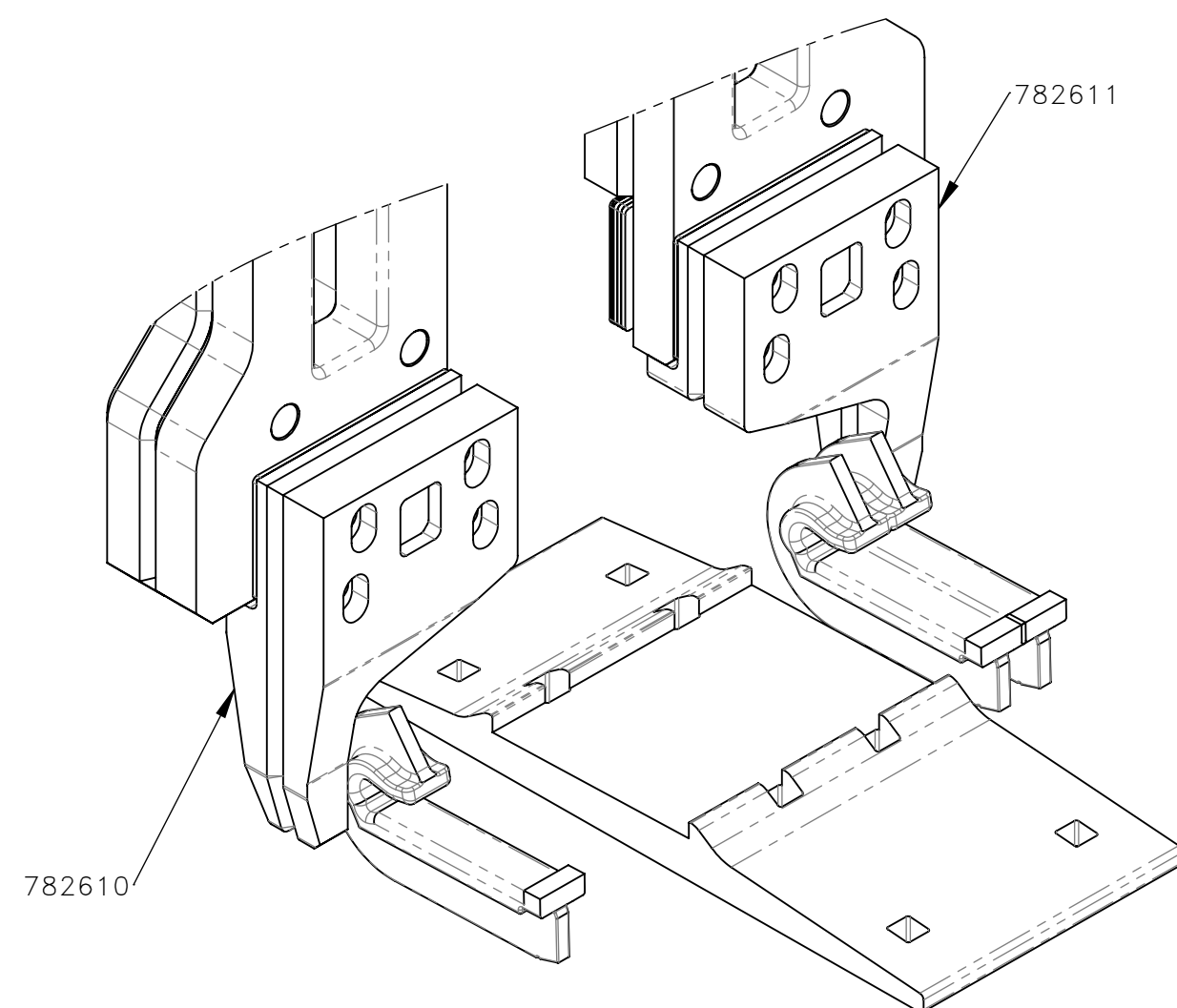
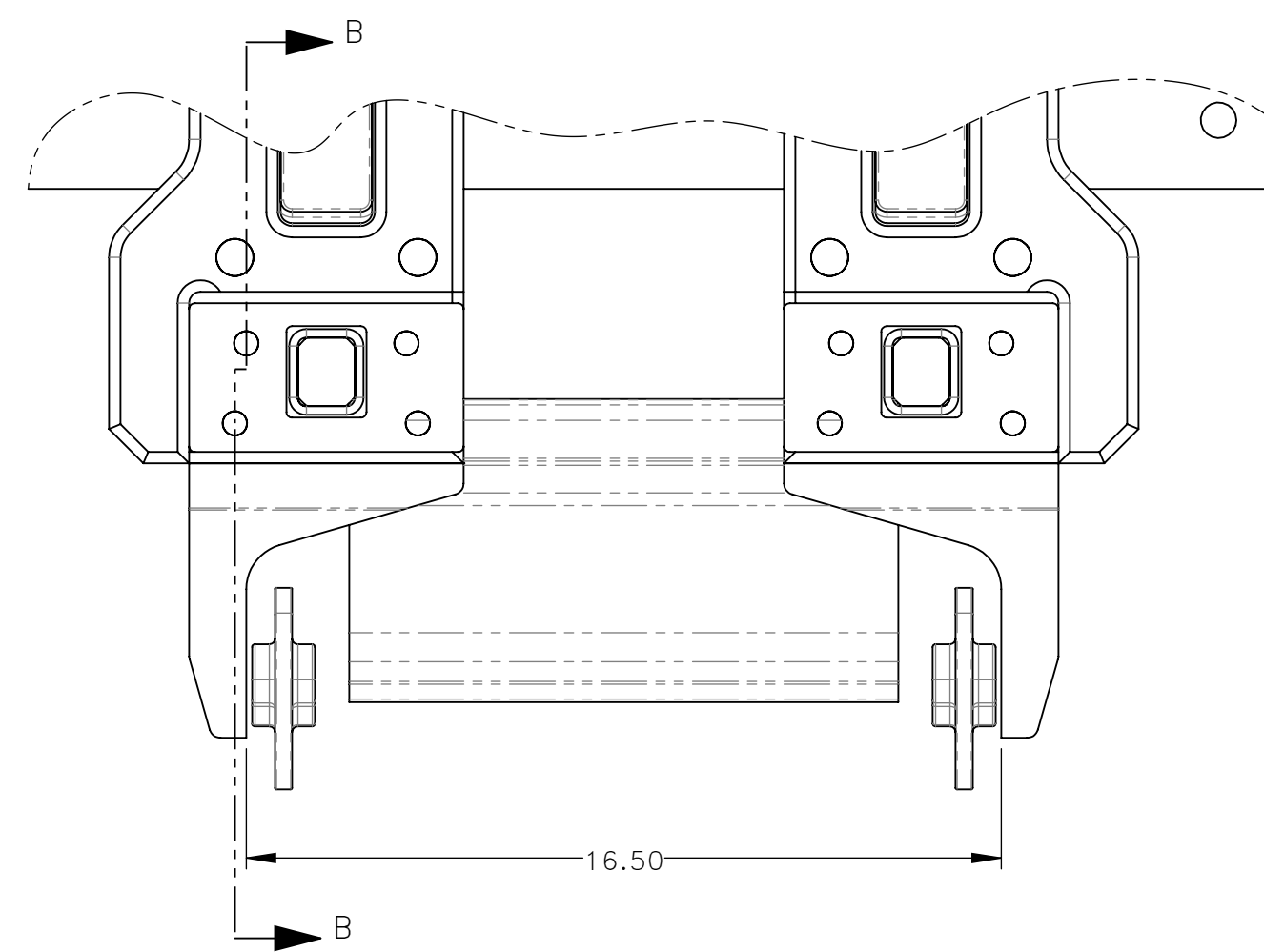
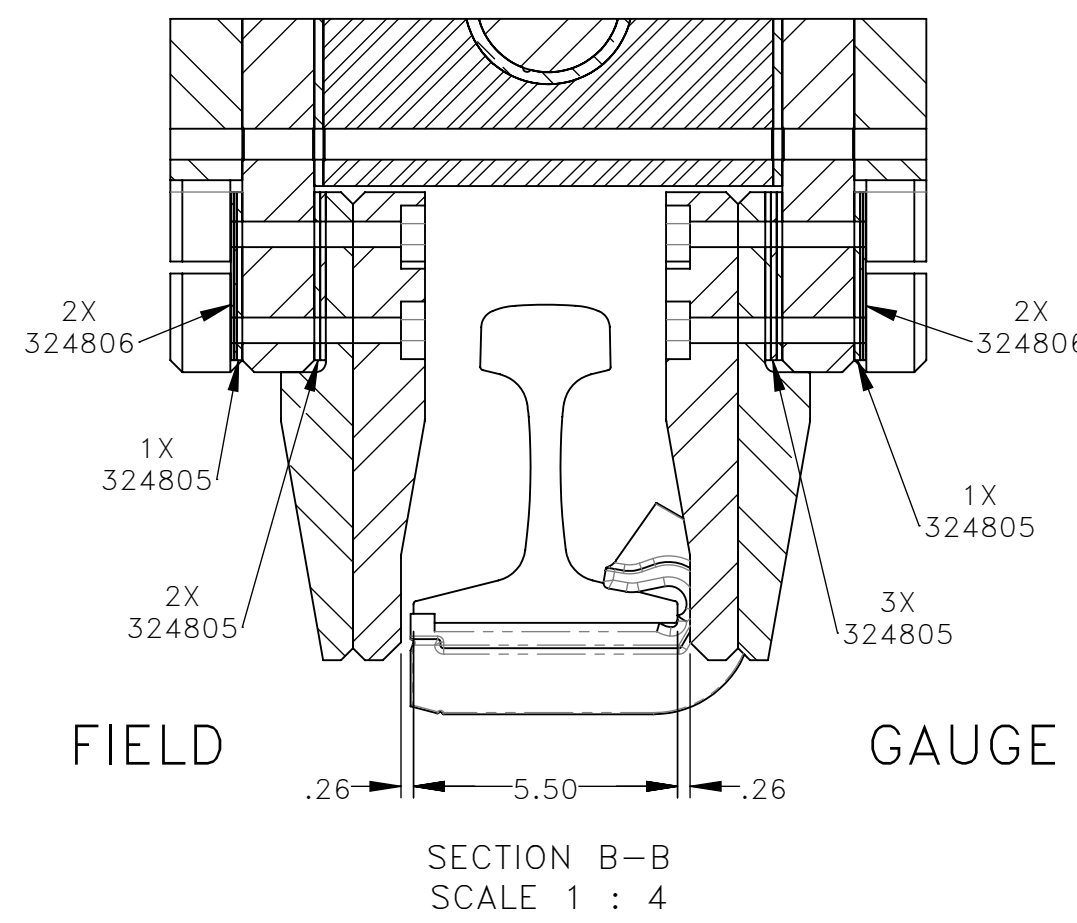

6" RAIL-SQUEEZE/ADJUST

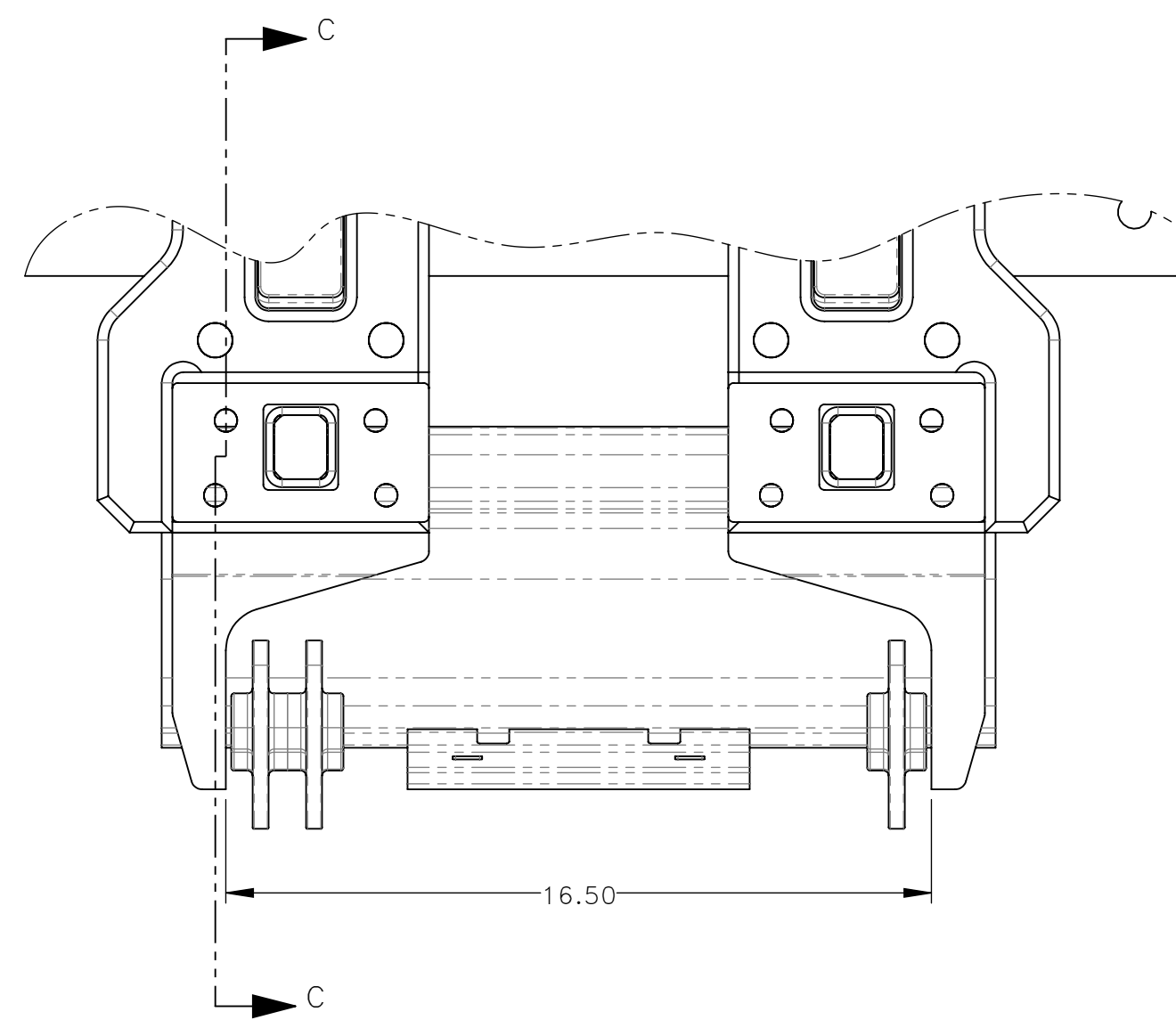
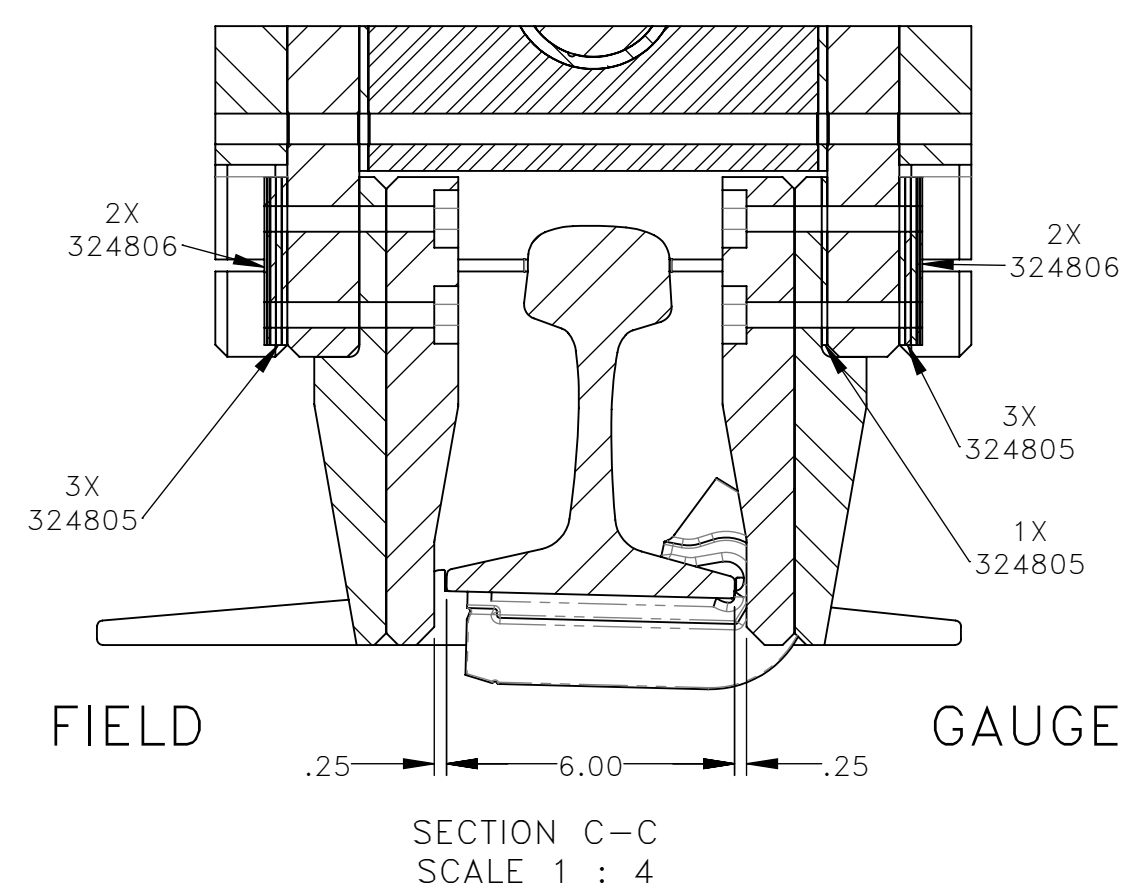

ANCHOR SQUEEZE/ADJUST TOOLS

REV	EN	DESCRIPTION	DATE	DRN
1	00845	NEW RELEASE	9-24	AP
DIMENSION TOLERANCES UNLESS OTHERWISE SPECIFIED				
LINEAR		.XX=±.03	.XXX=±.010	KERF ALLOW.
ANGULAR		X'=±1°	X.X'=±.5°	
SURFACE FINISH		125	SMOOTH ALL SHARP EDGES CLEAN ALL WELDS	
THIS PRINT AND ALL INFORMATION WITHIN BELONGS TO RACINE RAILROAD PRODUCTS				
RACINE RAILROAD PRODUCTS RACINE, WISCONSIN USA				
DESCRIPTION				
INSTRUCTIONS, DASP TOOLS				
MATERIAL TYPE				
USED ON		932596	SCALE	DATE
DRN		AP	1:12	09-16-24
DWG SIZE		D	WEIGHT (LBS)	N/A
CATALOG		N	JOB NO	RD230001
DWG NO		800429	SHEET	1 OF 3

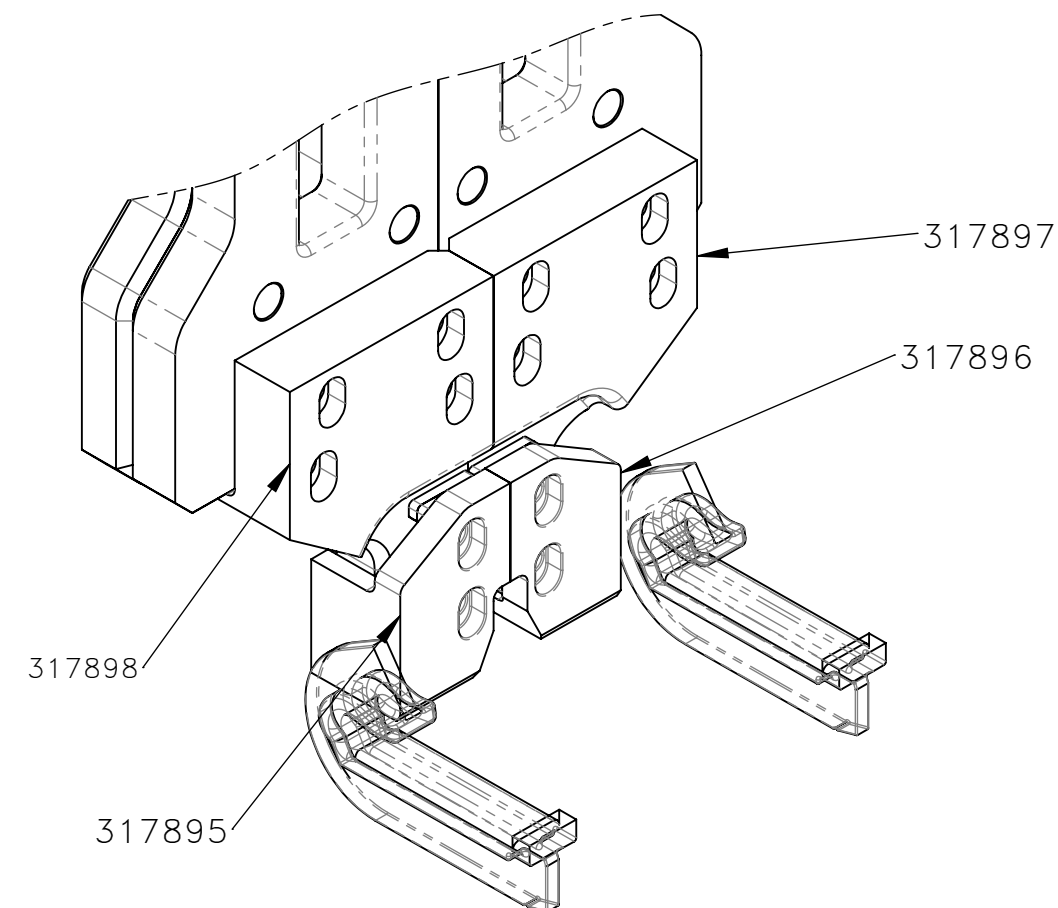

5" RAIL-SPREAD

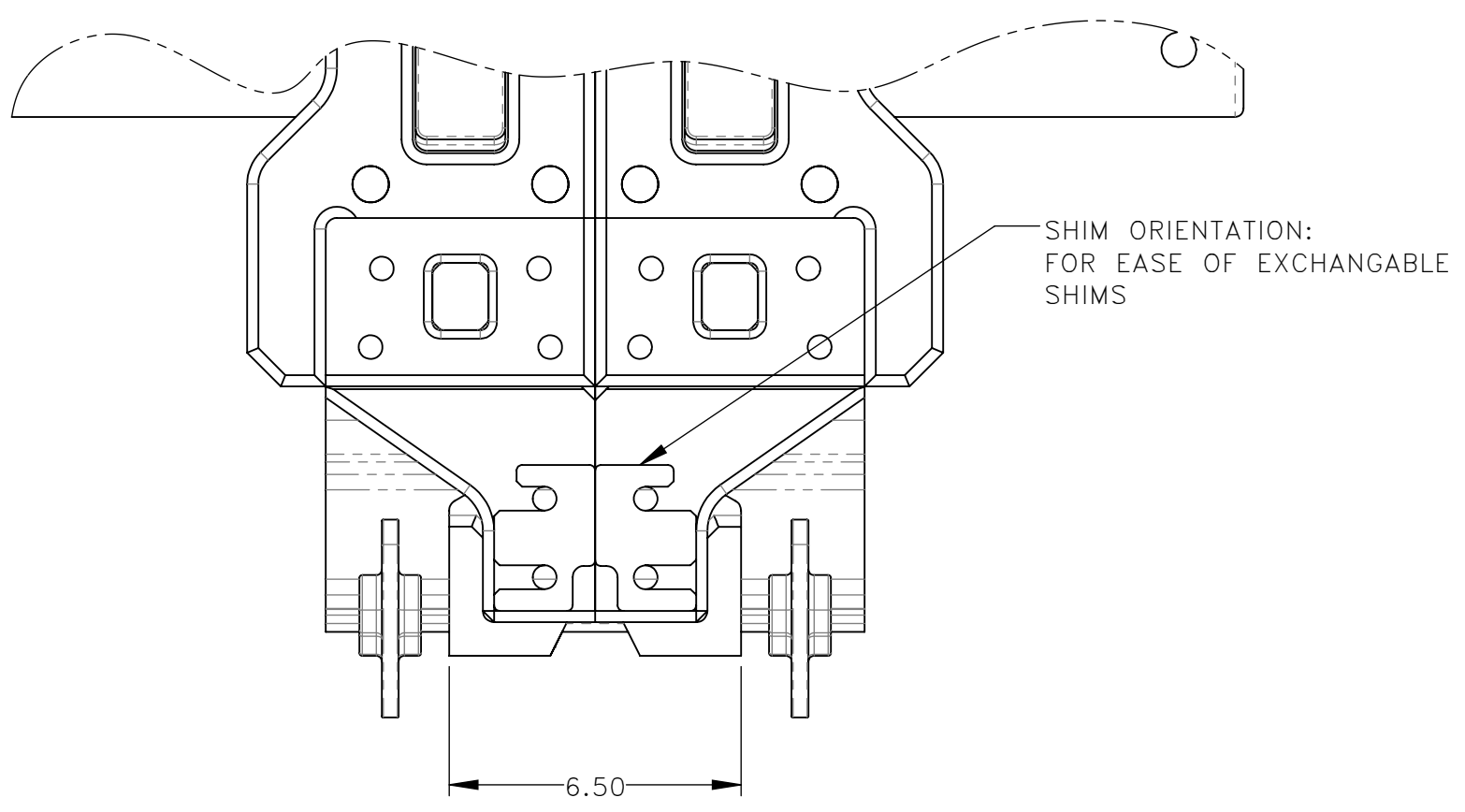
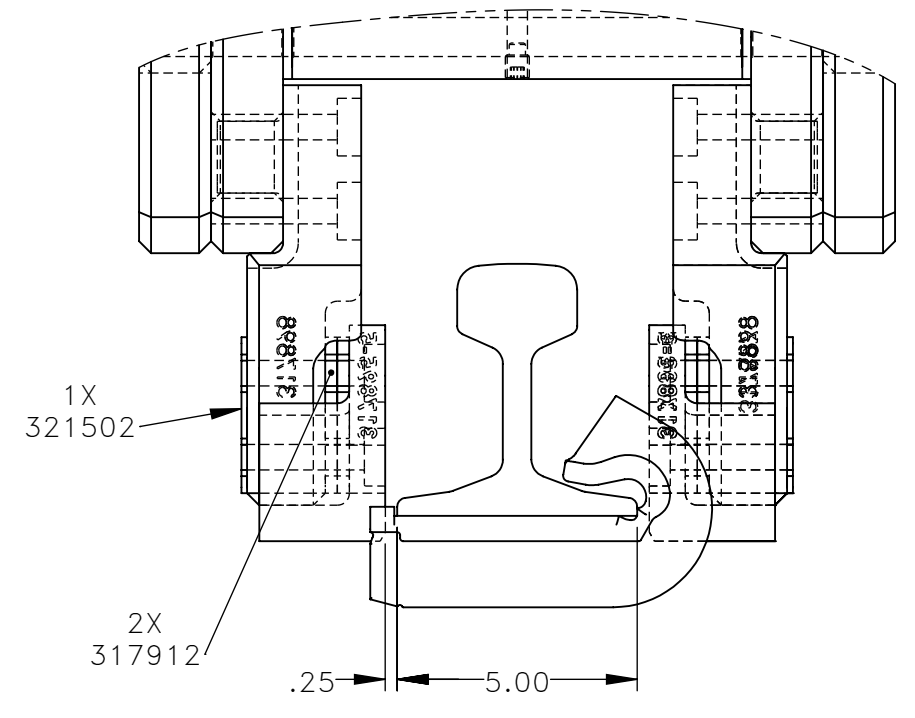

THE ADDITION OF 321502 SHIM CAN BE UTILIZED TO PROVIDE FINER ADJUSTMENTS OF A TIGHTER CLEARANCE BETWEEN TOOLS AND RAIL.

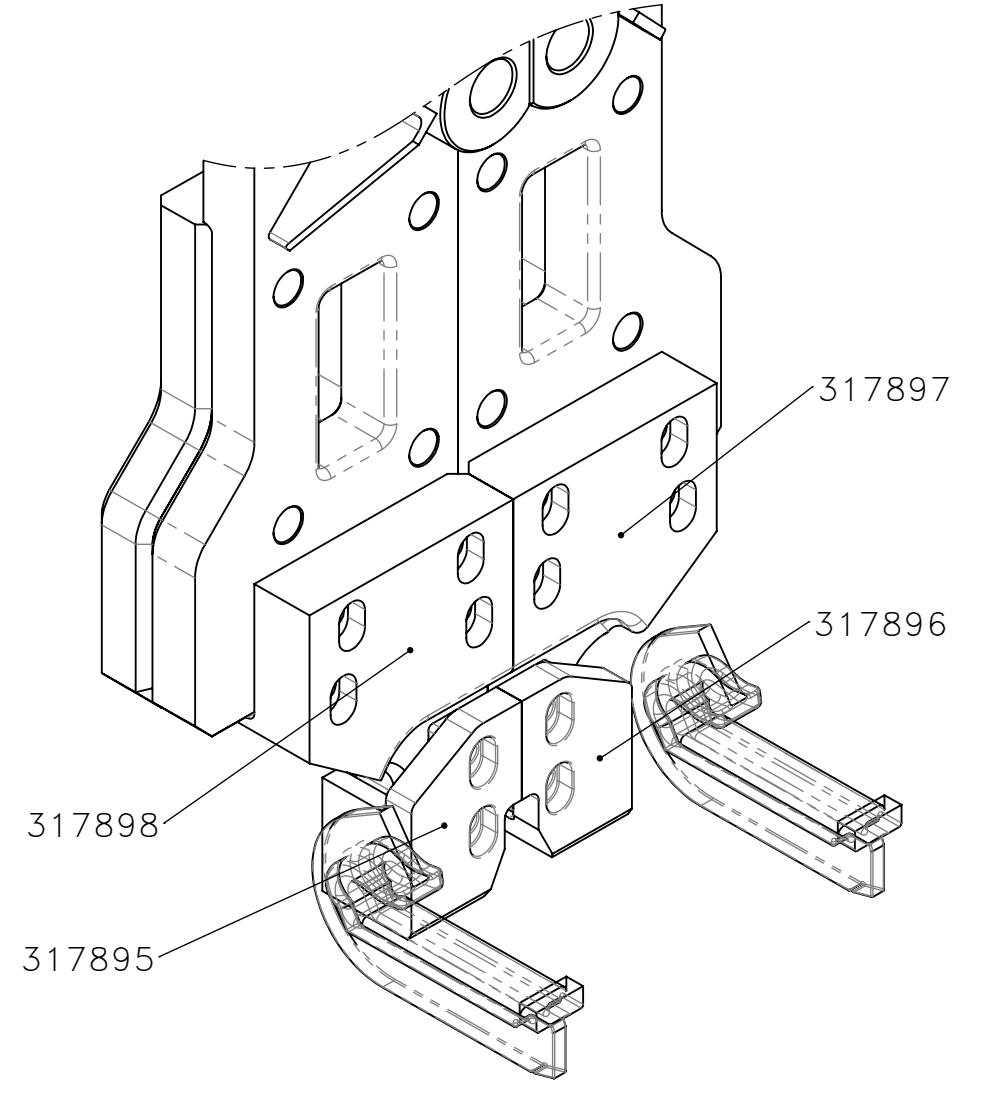

5.5" RAIL-SPREAD

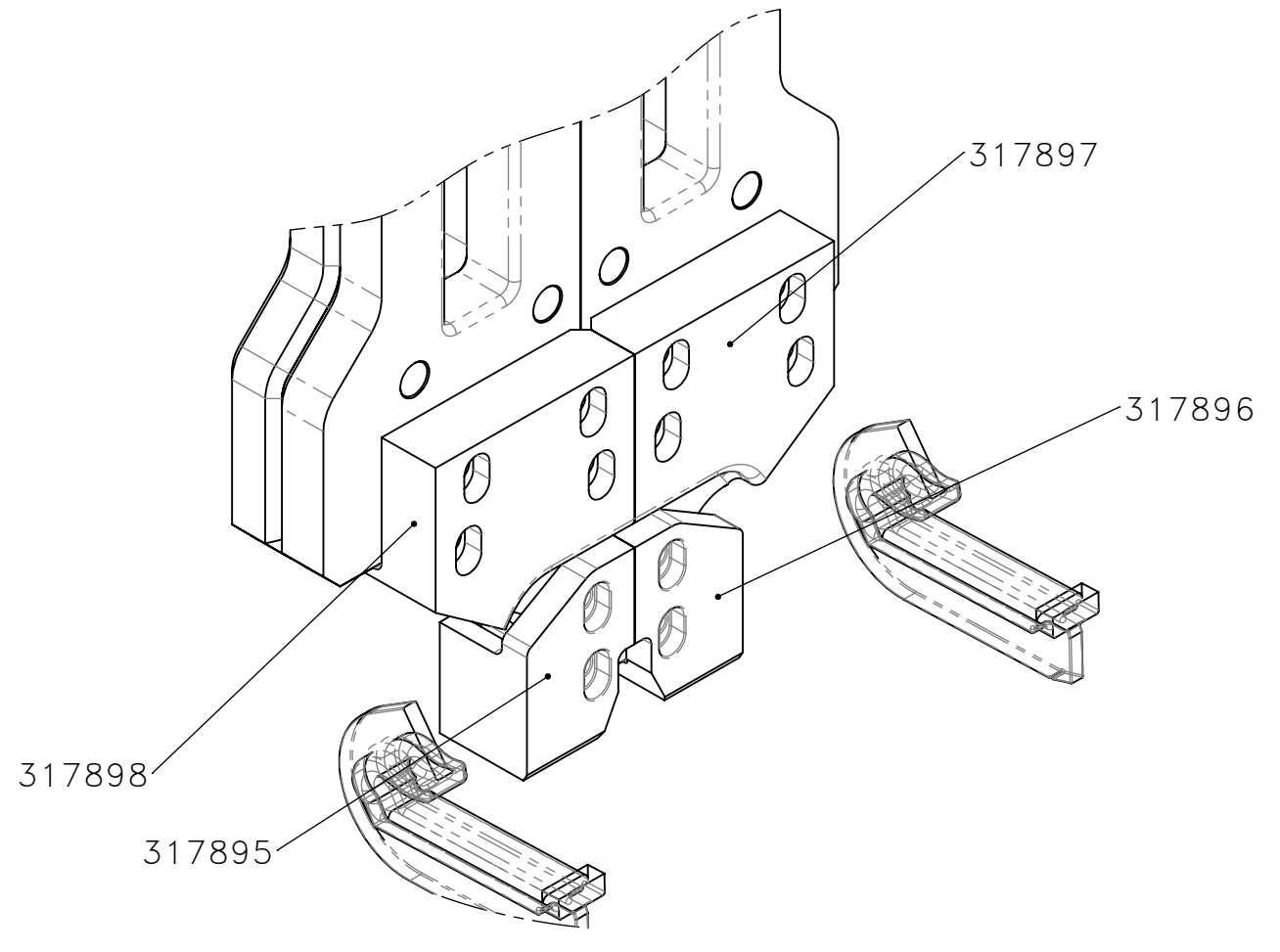
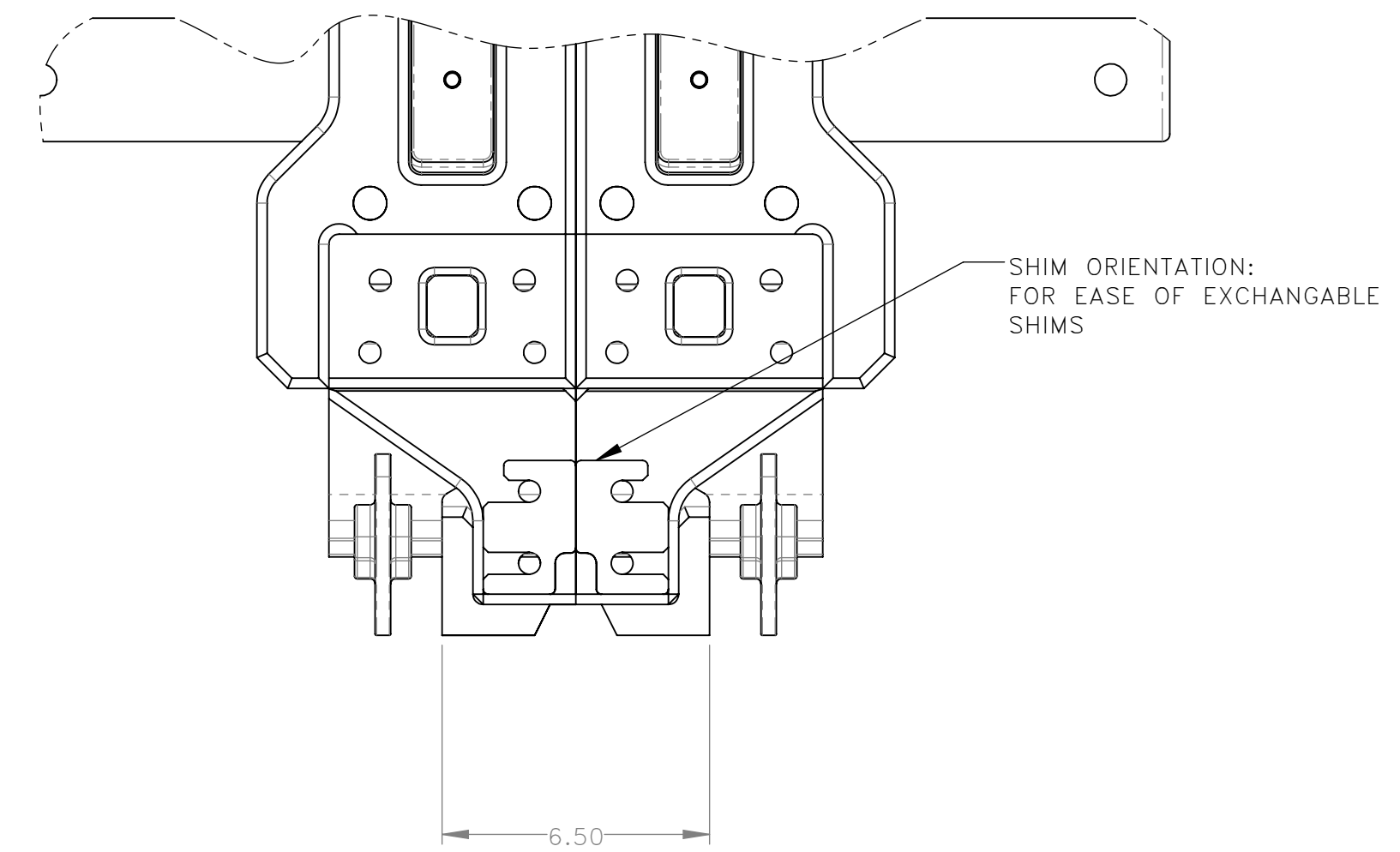
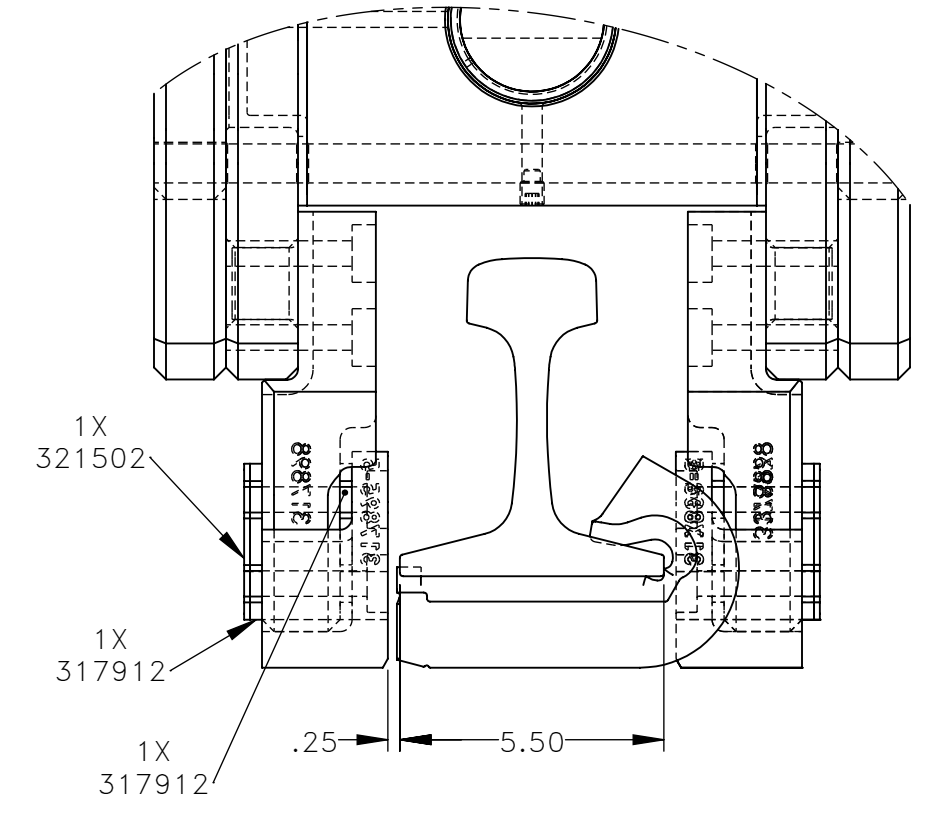

6" RAIL-SPREAD

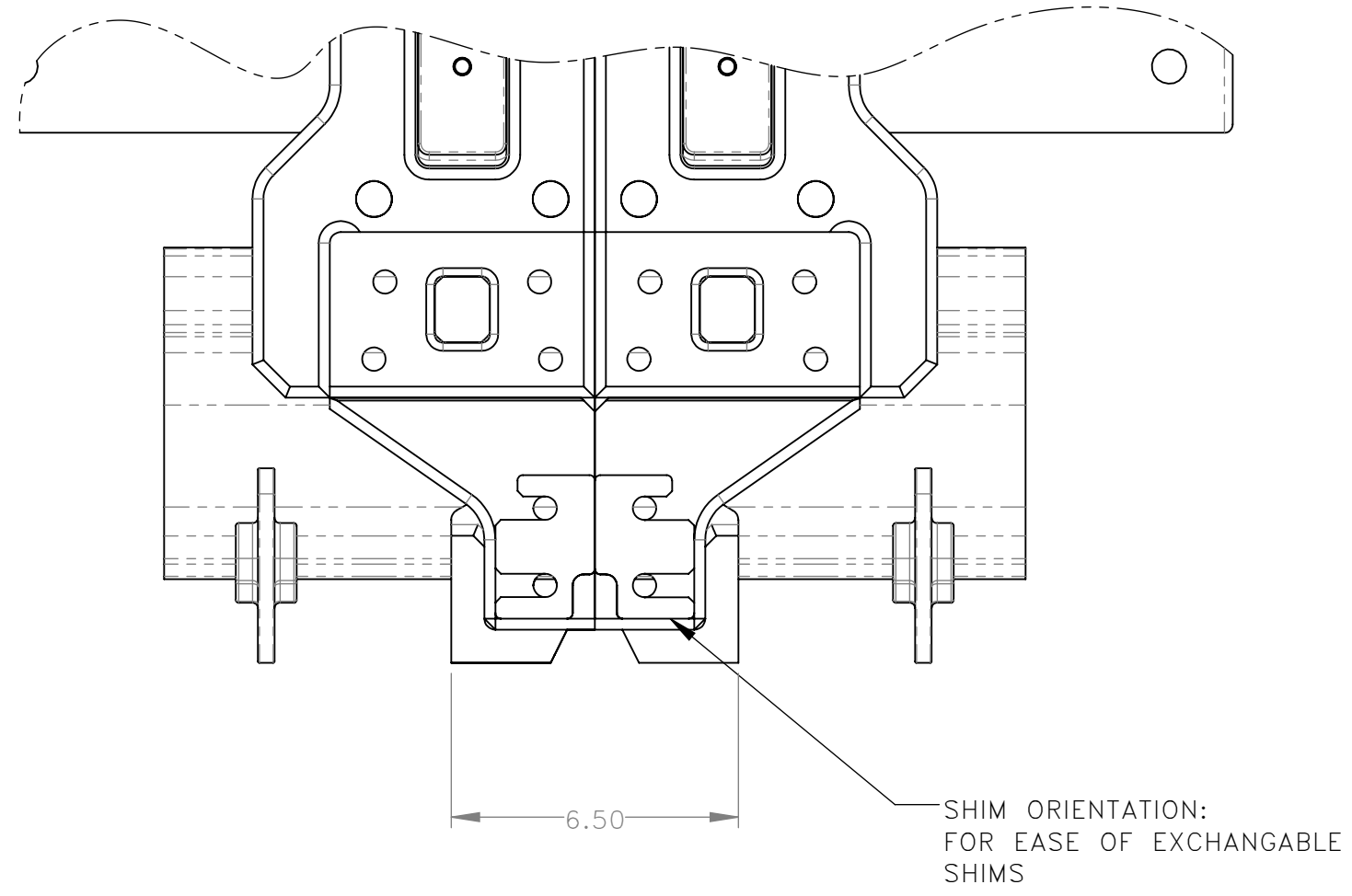
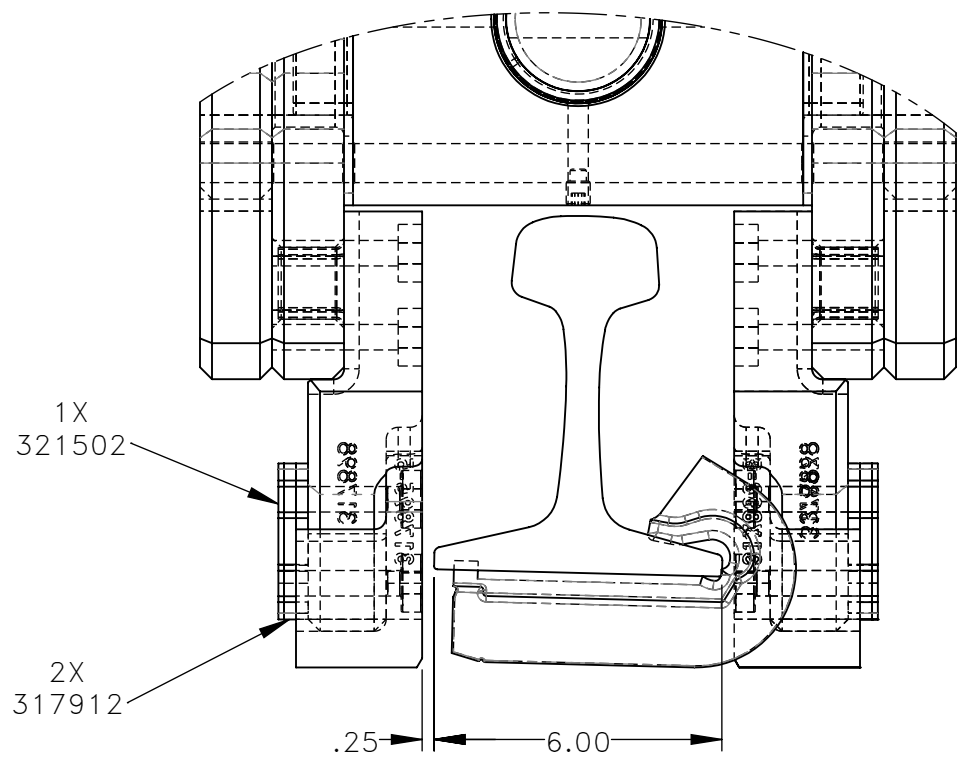

ANCHOR SPREAD TOOLS

REV	EN	DESCRIPTION	DATE	DRN
1	00845	NEW RELEASE	9-24	AP
DIMENSION TOLERANCES UNLESS OTHERWISE SPECIFIED				
LINEAR	.XX=±.03	.XXX=±.010	KERF ALLOW.	
ANGULAR	X°=±1°	X.X°=±.5°		
SURFACE FINISH		125	SMOOTH ALL SHARP EDGES CLEAN ALL WELDS	
THIS PRINT AND ALL INFORMATION WITHIN BELONGS TO RACINE RAILROAD PRODUCTS				
RACINE RAILROAD PRODUCTS RACINE, WISCONSIN USA				
DESCRIPTION				
INSTRUCTIONS, DASP TOOLS				
MATERIAL TYPE				
USED ON		REFERENCE	SCALE	DATE
		932596	1:12	09-16-24
DRN	WEIGHT (LBS)	JOB NO	SHEET	
AP	N/A	RD230001	2 OF 3	
DWG SIZE	CATALOG	DWG NO		
D	N	800429		

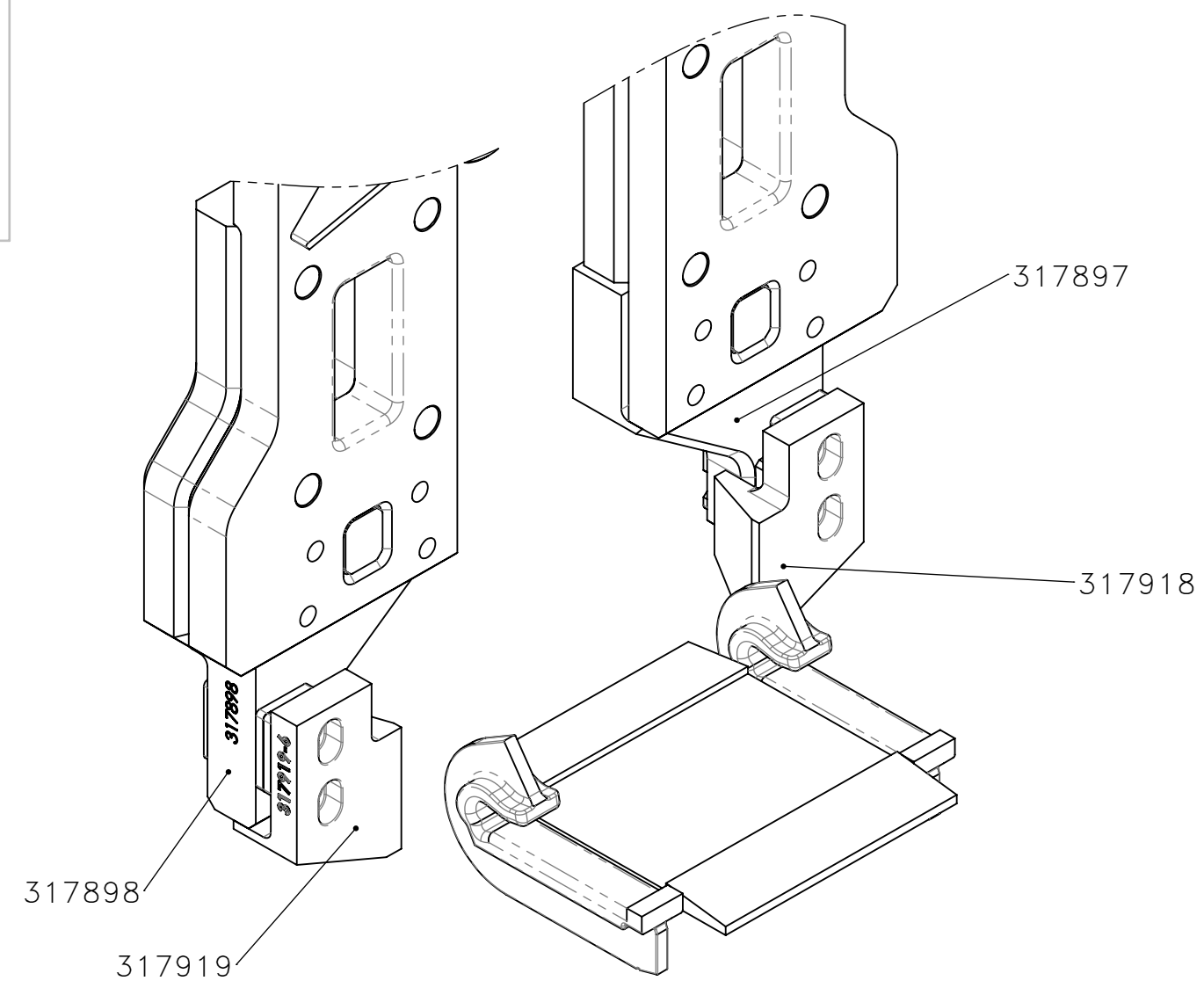

5" RAIL-SPREAD WITH PLATE

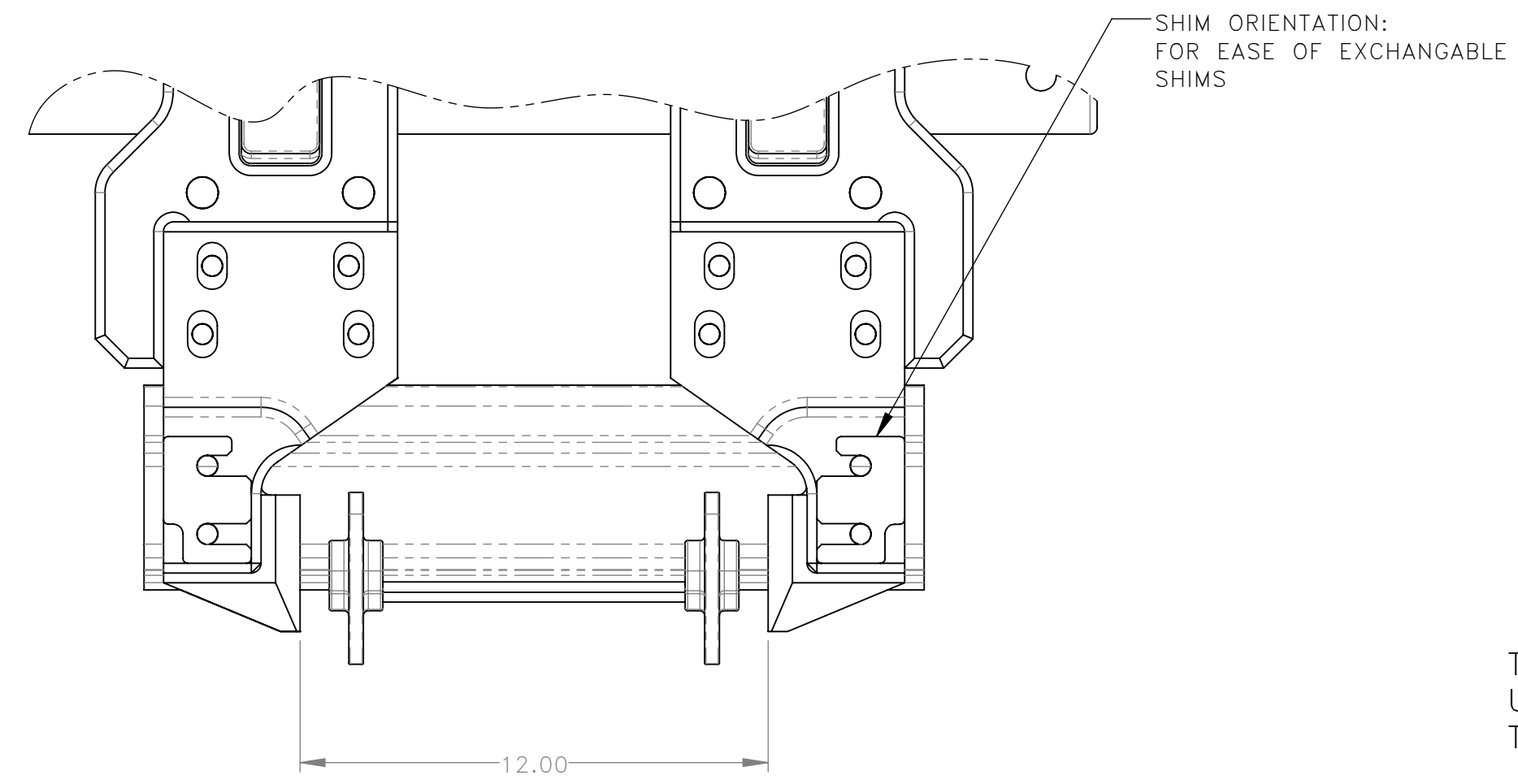
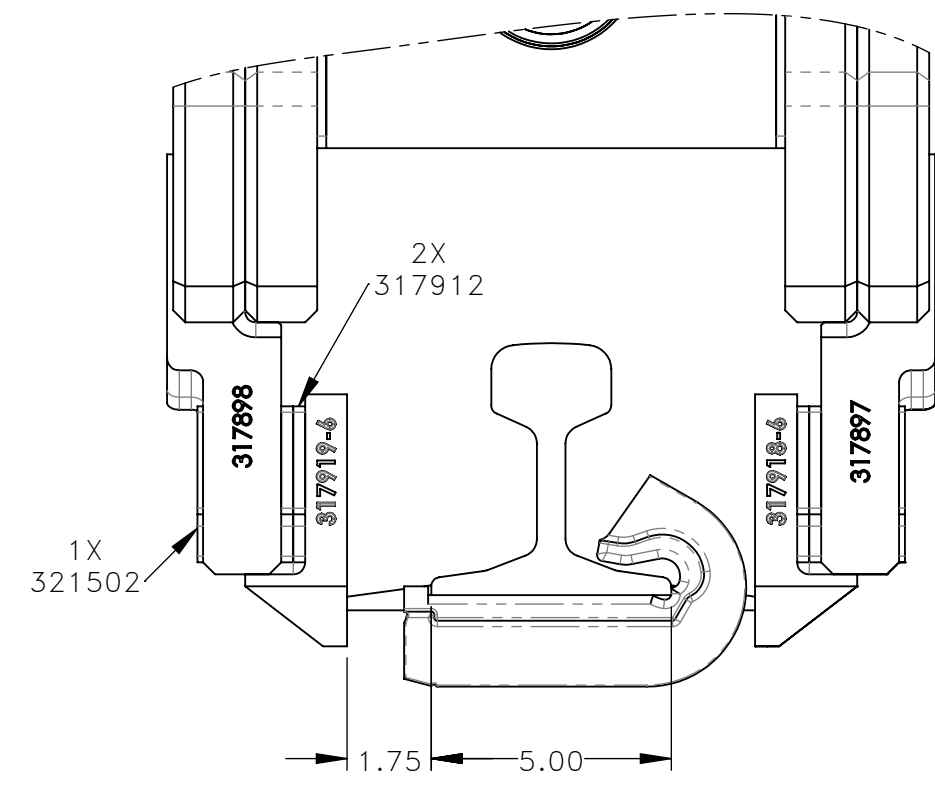

THE ADDITION OF 321502 SHIM CAN BE UTILIZED TO PROVIDE FINER ADJUSTMENTS OF A TIGHTER CLEARANCE BETWEEN TOOLS AND RAIL.

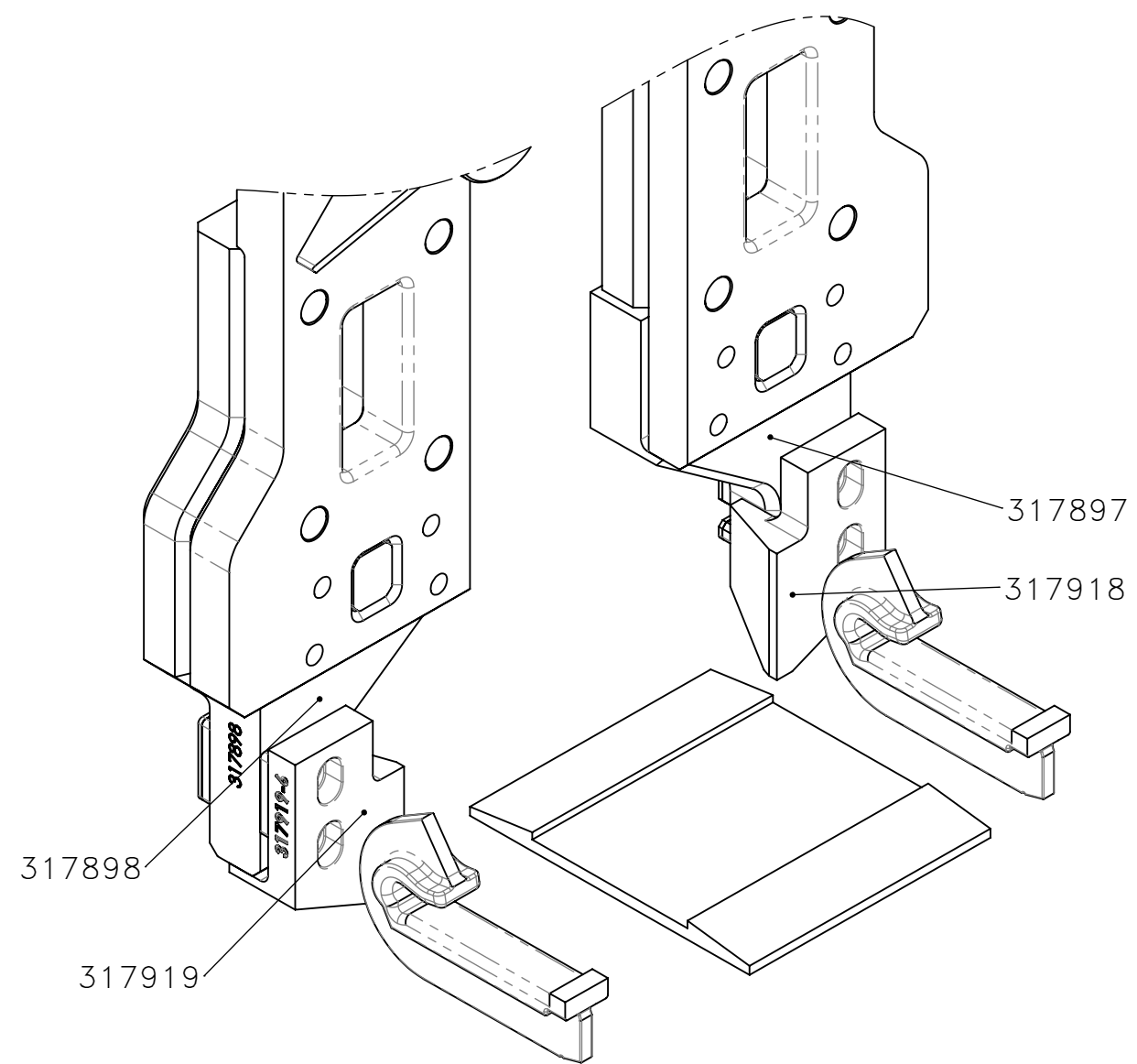

5.5" RAIL-SPREAD WITH PLATE

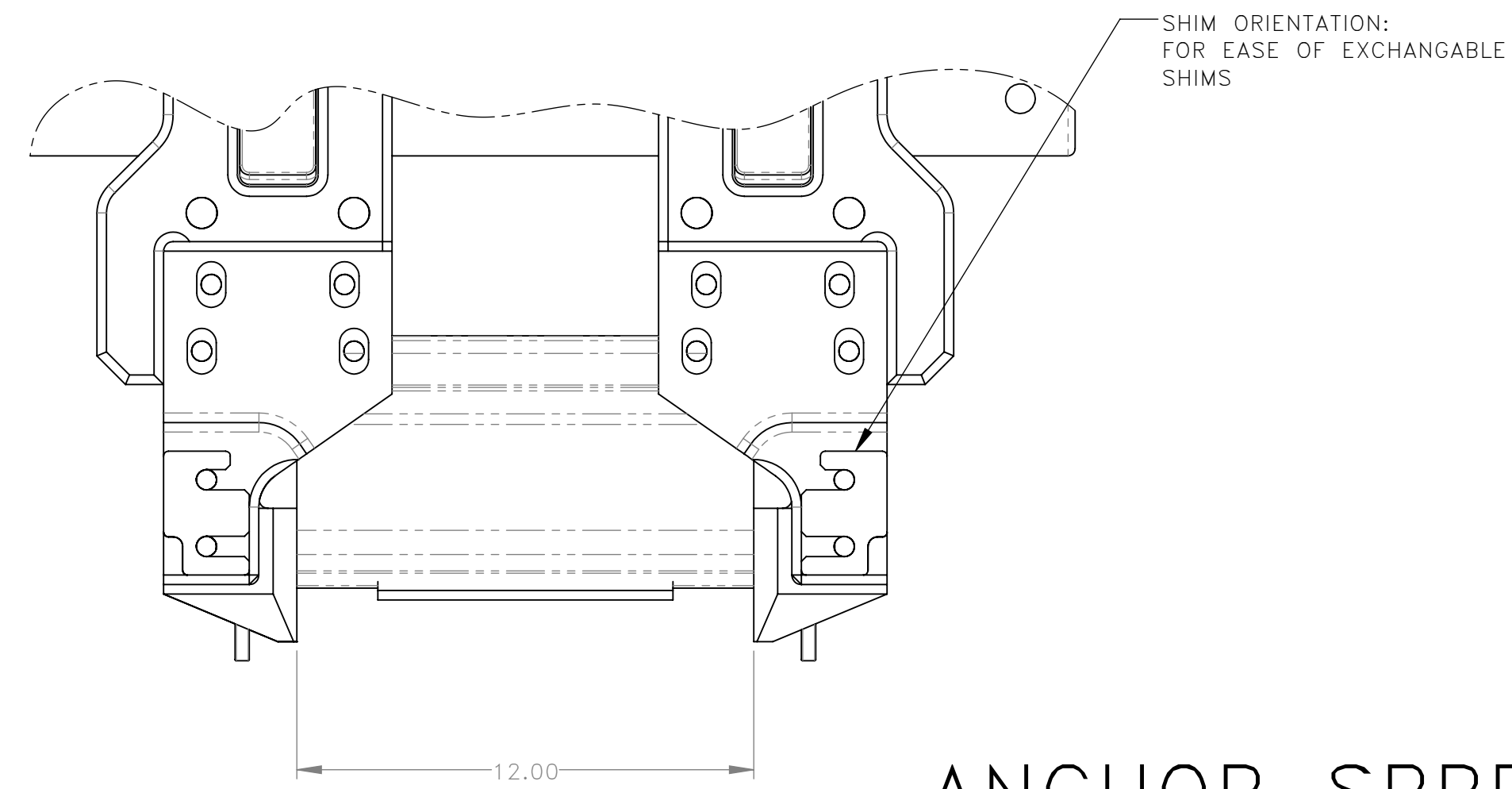
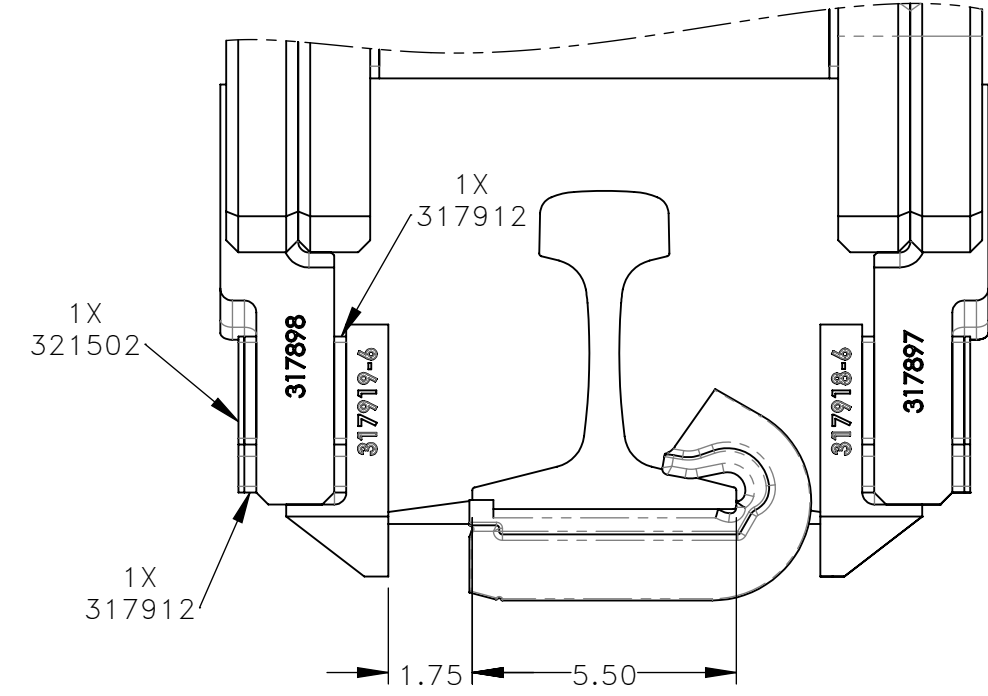

ANCHOR SPREAD PLATE TOOLS

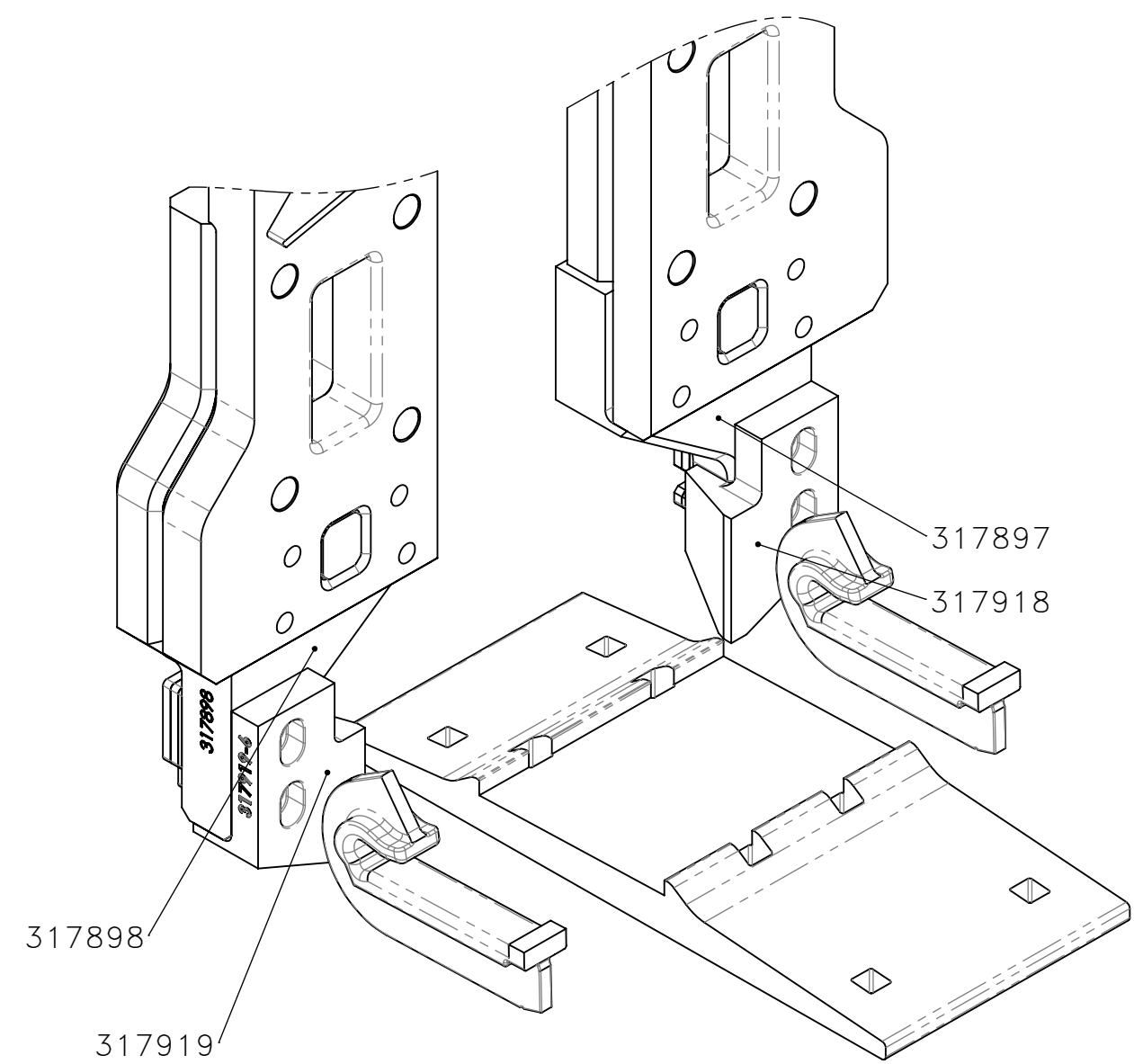

6" RAIL-SPREAD WITH PLATE

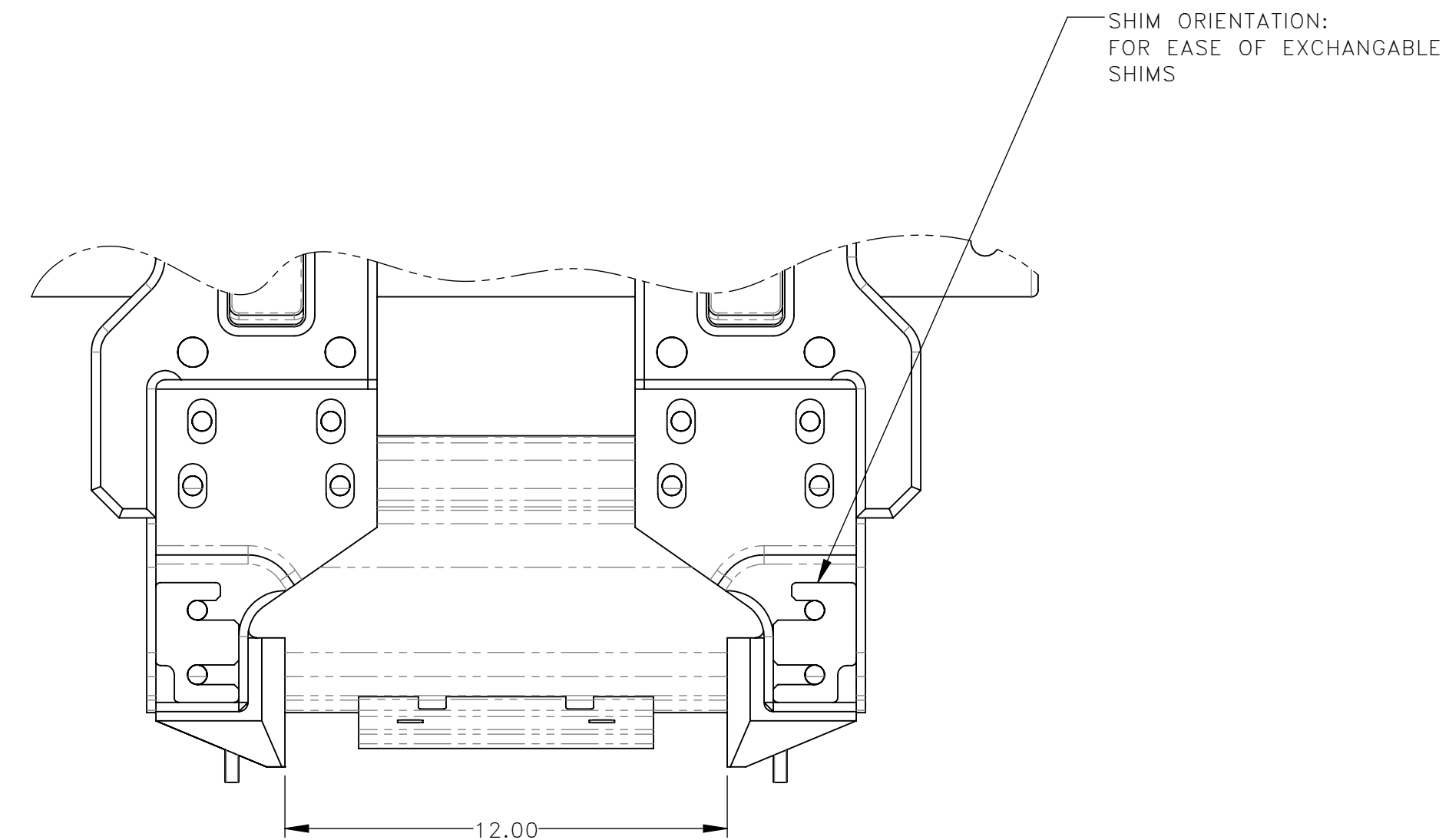
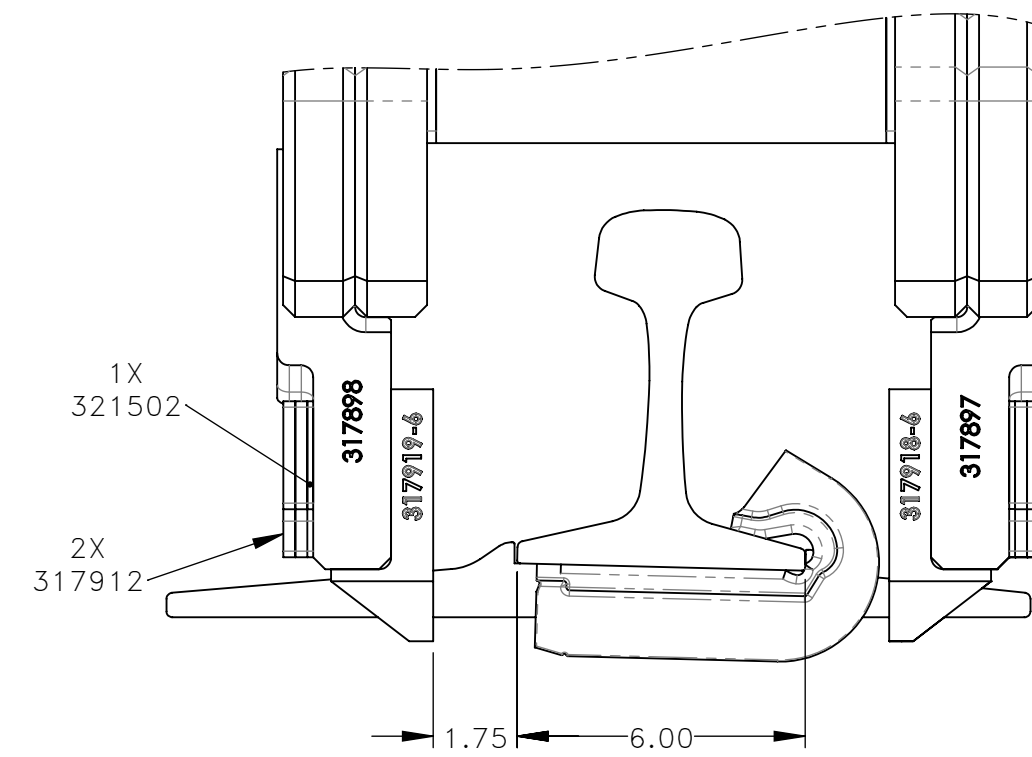

REV	EN	DESCRIPTION	DATE	DRN
1		00845 NEW RELEASE	9-24	AP
DIMENSION TOLERANCES UNLESS OTHERWISE SPECIFIED				
LINEAR	.XX=±.03	.XXX=±.010	KERF ALLOW.	
ANGULAR	X'=±1°	X.X'=±.5°		
SURFACE FINISH		125	SMOOTH ALL SHARP EDGES CLEAN ALL WELDS	
THIS PRINT AND ALL INFORMATION WITHIN BELONGS TO RACINE RAILROAD PRODUCTS				
RACINE RAILROAD PRODUCTS RACINE, WISCONSIN USA				
DESCRIPTION				
INSTRUCTIONS, DASP TOOLS				
MATERIAL TYPE		REFERENCE		
USED ON	932596	SCALE	DATE	
		1:12	09-16-24	
DRN	WEIGHT (LBS)	JOB NO	SHEET	
AP	N/A	RD250001	3 OF 3	
DWG SIZE	CATALOG	DWG NO		
D	N		800429	