

Service Bulletin

Maintenance of Way Equipment

Date: 11.20.2024

RRP Service Bulletin No: RRP SB394

Title: ATPI Dual PO Check Valve Kit

Rating:



ALERT
 (Potential Problem)



INFORMATION
 (Action Is Optional)



DIRECTIVE
 (Action Is Required)



PRODUCT IMPROVEMENT
 (Enhance Product)

Product Series: Advanced Tie Plate Inserter [ATPI]

Serial No:

These machines require, PO check kit 793210

ATPI-034	932587	RELAM/BNSF	X3800203
ATPI-041	932587	RELAM/BNSF	X3800204
ATPI-044	932587	RELAM/BNSF	X3800201
ATPI-045	932587	BNSF	X3800196
ATPI-046	932587	BNSF	X3800197
ATPI-047	932587	BNSF	X3800198
ATPI-068	931587	UPRR	RLPI-2302
ATPI-069	931587	UPRR	RLPI-2401

ATPI-048	932587	BNSF	X3800199
ATPI-049	932587	BNSF	X3800200
ATPI-050	932587	BNSF	X3800195
ATPI-065	932587	BNSF	X3800207
ATPI-066	932587	BNSF	X3800208

These machines require Kit # 793210 and Bracket 793213

ATPI-015	932574	BNSF	X3800192
ATPI-018	930587	BNSF	X3002502

Summary: Machines need to have a PO check kit installed to prevent the center insert cylinders from drifting out during field insert operation.

Action: Install Kit # 793210 ATPI Dual PO Check Valve Kit. See attached sheets for details.

Completion / Resolution: Continue with normal machine operation after installing service kit 793210.

Contact: If you have any questions or we can be of any service, please contact the Racine Railroad Products Service Department at (262)-637-9681 or fieldservice@racinerailroad.com.

NO.	QTY	DESCRIPTION	PART NO.
1	AR	LOCTITE, 242	008806
2	AR	LOCTITE, PRIMER T	008825
3	4	NUT, HEX ES: .31-18	450578
4	8	ADAPTER, #6 JIC(M) X #6 SAE(M)	460157
5	4	ELBOW, 45°: #6 JIC(M) X #6 JIC(F)	460235
6	2	VALVE, CHECK: P.O. DUAL	466197
7	4	WASHER, FLT: .31	491259
8	4	SCR, HEX FLG: .31-18 X 2.25	491765
9	1	PO CHECK VALVE SWAP INSTRUCTIONS	800426

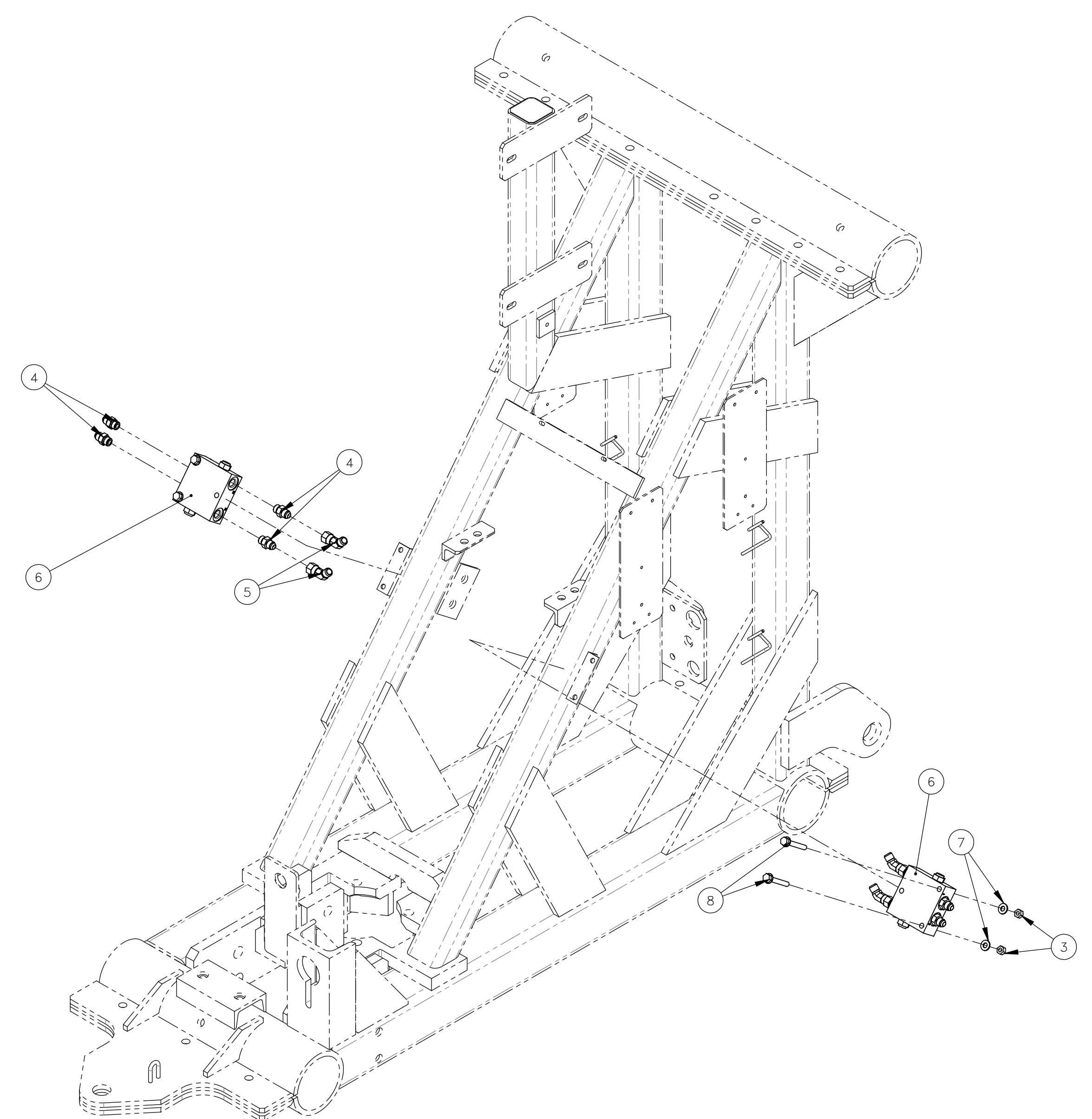
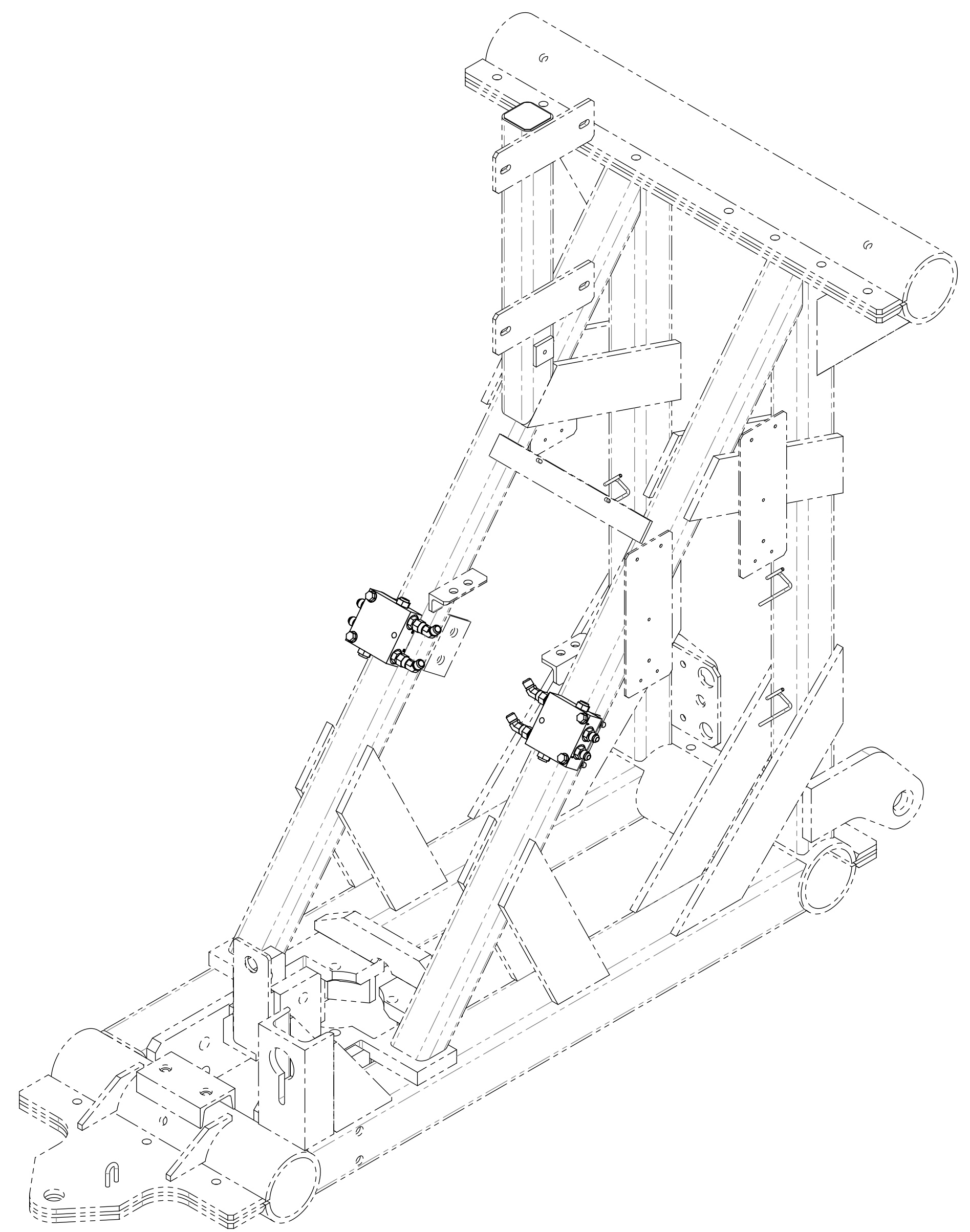

REV	EN	DESCRIPTION	DATE	DRN
1	00841	NEW RELEASE	8-24	LHM

DIMENSION TOLERANCES UNLESS OTHERWISE SPECIFIED

LINEAR	.XX=±.03	.XXX=±.010	KERF ALLOW.
ANGULAR	X°=±1°	X.X°=±.5°	

SURFACE FINISH NOT TO EXCEED 125 ✓ SMOOTH ALL SHARP EDGES CLEAN ALL WELDS

THIS PRINT AND ALL INFORMATION WITHIN BELONGS TO RACINE RAILROAD PRODUCTS

RACINE RAILROAD PRODUCTS
RACINE, WISCONSIN USA

DESCRIPTION
ATPI DUAL PO CHECK VALVE KIT

MATERIAL TYPE
SEE BOM

USED ON	717640	SCALE	DATE
		1:12	08-22-24

DRN	WEIGHT (LBS)	JOB NO	SHEET
LHM	4.80	RD150003	1 OF 1

DWG SIZE	CATALOG	DWG NO
D	K	793210

NO.	QTY	DESCRIPTION	PART NO.
1	REF	LOCTITE, 242	008806
2	REF	LOCTITE, PRIMER T	008825
3	REF	NUT, HEX ES: .31-18	450578
4	REF	ADAPTER, #6 JIC(M) X #6 SAE(M)	460157
5	REF	ELBOW, 45°: #6 JIC(M) X #6 JIC(F)	460235
6	REF	VALVE, CHECK: P.O. DUAL	466197
7	REF	WASHER, FLT: .31	491259
8	REF	SCR, HEX FLG: .31-18 X 2.25	491765

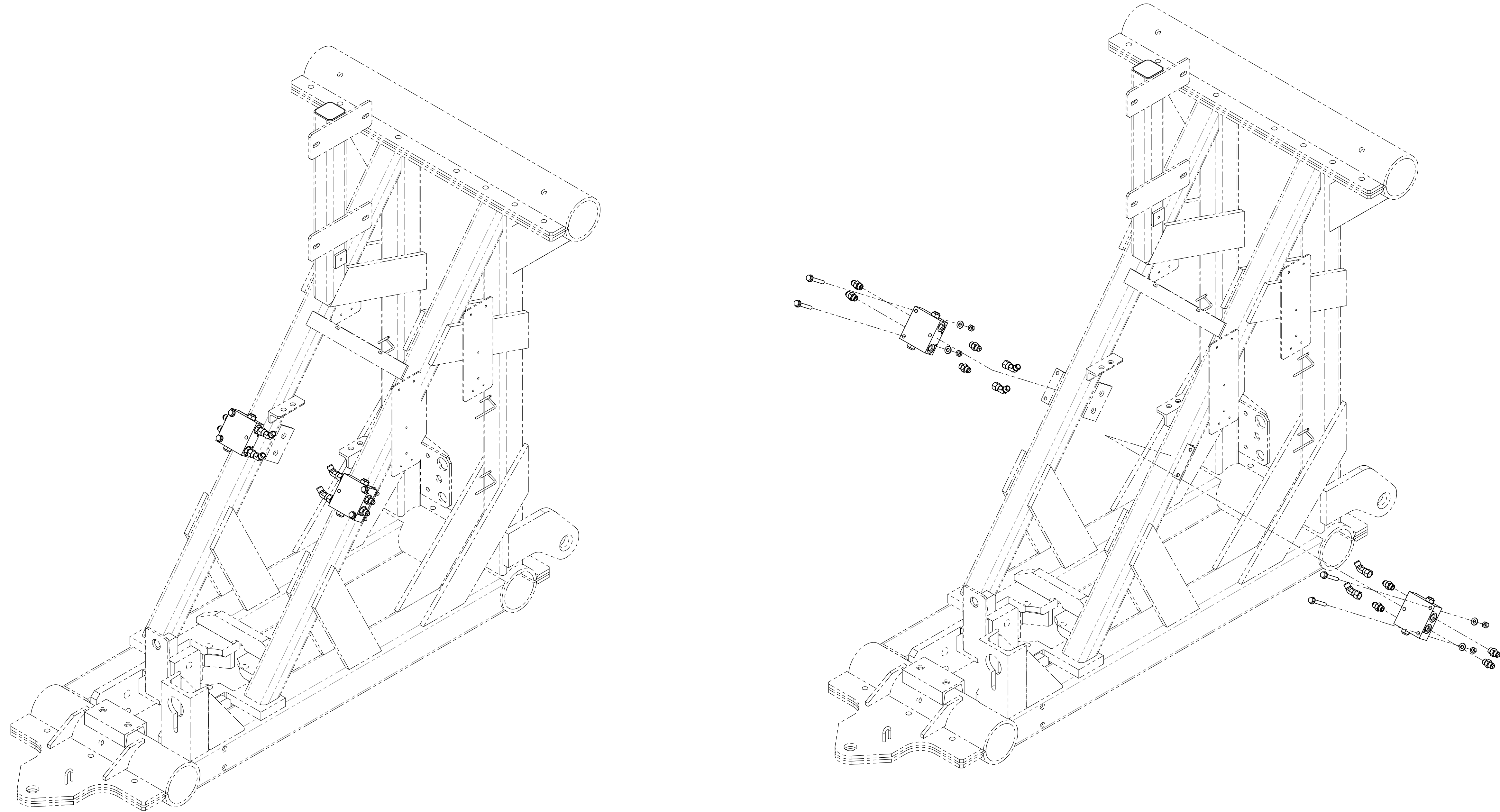

REV	EN	DESCRIPTION	DATE	DRN
1	00841	NEW RELEASE	8-24	LHM

DIMENSION TOLERANCES UNLESS OTHERWISE SPECIFIED

LINEAR	.XX=±.03	.XXX=±.010	KERF ALLOW.
ANGULAR	X°=±1°	X.X°=±.5°	

SURFACE FINISH NOT TO EXCEED 125√ SMOOTH ALL SHARP EDGES
CLEAN ALL WELDS

THIS PRINT AND ALL INFORMATION WITHIN BELONGS TO RACINE RAILROAD PRODUCTS

RACINE RAILROAD PRODUCTS
RACINE, WISCONSIN USA

DESCRIPTION
INSTRUCTIONS, ATPI
DUAL PO CHK VLV KIT

MATERIAL TYPE
SEE BOM

USED ON	717640	SCALE	DATE
		1:12	08-23-24

DRN	WEIGHT (LBS)	JOB NO	SHEET
		RD150003	1 OF 3

DWG SIZE	CATALOG	DWG NO
D	N	800426

ATPI P.O. CHECK INSTRUCTIONS

1. PERFORM LOCK OUT PROCEDURE TO THE MACHINE. MAKE SURE THE HYDRAULIC PRESSURE IS RELEASED AND THE WORKHEAD IS IN A SAFE STATE.
2. REMOVE THE P CLAMPS HOLDING THE WIRES AND GREASE LINES IN PLACE NEXT TO THE EXISTING BULK HEADS.
3. INSTALL THE (460157) ADAPTER X4 ON BOTH OF THE (466197) VALVES.
4. MARK AND REMOVE THE HOSES FROM THE EXISTING BULKHEAD A AND B ON BOTH SIDES.
5. REMOVE THE 45* ADAPTER THAT IS ON THE CMA SIDE OF THE BULKHEAD AND IT WILL BE REUSED ON THE NEW VALVE.
6. INSTALL THE NEW VALVE TO THE WELDMENT ON THE WORKHEAD FRAME ABOVE THE OLD BULKHEAD USING THE SUPPLIED HARDWARE (MAKE SURE IT IS ORIENTED CORRECTLY A & B TOWARDS THE CMA).
7. CONNECT HOSES COMING FROM THE CMA TO THE A & B PORTS (BE AWARE OF MOVING PARTS AND LENGTH NEEDED WHILE ROUTING HOSES).
8. INSTALL THE 45* ADAPTERS ON THE C1 AND C2 PORTS BUT LEAVE LOOSE.
9. CONNECT AND TIGHTEN THE HOSES TO THE C1 AND C2 PORTS (BE AWARE OF MOVING PARTS AND LENGTH NEEDED WHILE ROUTING HOSES).
10. ZIP TIE ALL LOOSE HOSES AND CABLES.
11. UNLOCK MACHINE.
12. E PUMP MACHINE TO FILL UP EMPTY HOSES.
13. USE MAINTENANCE MODE TO TEST THE FUNCTIONALITY, PLUMBING, AND MOVEMENT OF THE HOSES BEFORE GOING RIGHT BACK TO WORK.

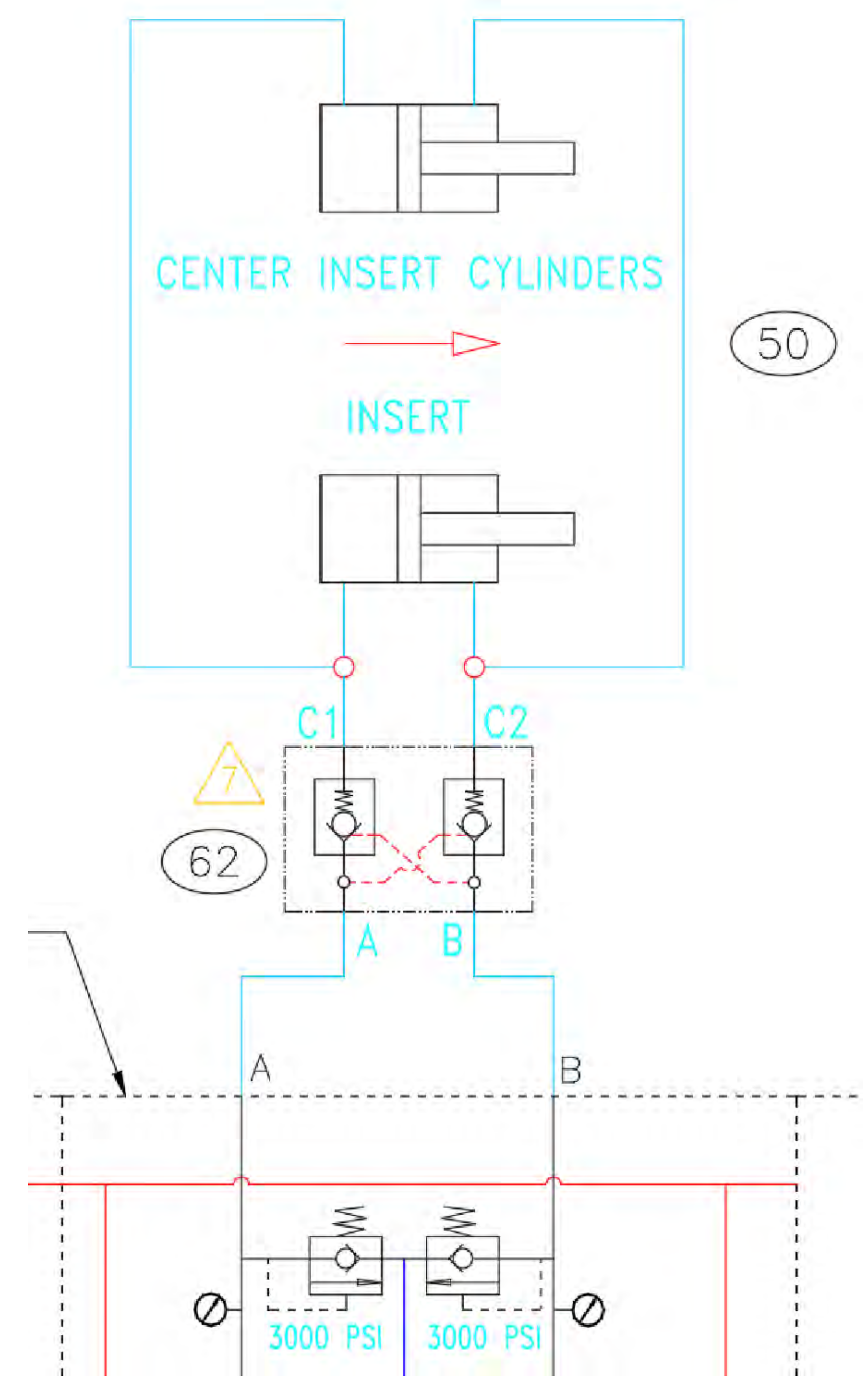

REV	EN	DESCRIPTION	DATE	DRN
1	00841	NEW RELEASE	8-24	LHM
DIMENSION TOLERANCES UNLESS OTHERWISE SPECIFIED				
LINEAR	.XX=±.03	.XXX=±.010	KERF ALLOW.	
ANGULAR	X°=±1°	X.X°=±.5°		
SURFACE FINISH NOT TO EXCEED		125	SMOOTH ALL SHARP EDGES CLEAN ALL WELDS	
THIS PRINT AND ALL INFORMATION WITHIN BELONGS TO RACINE RAILROAD PRODUCTS				
RACINE RAILROAD PRODUCTS RACINE, WISCONSIN USA				
DESCRIPTION INSTRUCTIONS, ATPI DUAL PO CHK VLV KIT				
MATERIAL TYPE SEE BOM				
USED ON	717640	SCALE	DATE	
		1:12	08-23-24	
DRN	WEIGHT (LBS)	JOB NO	SHEET	
		RD150003	2 OF 3	
DWG SIZE	CATALOG	DWG NO		
D	N	800426		



IMAGE 1



IMAGE 2



IMAGE 3



IMAGE 4



IMAGE 5



IMAGE 6

REV	EN	DESCRIPTION	DATE	DRN
1	00841	NEW RELEASE	8-24	LHM
DIMENSION TOLERANCES UNLESS OTHERWISE SPECIFIED				
LINEAR	.XX=±.03	.XXX=±.010	KERF ALLOW.	
ANGULAR	X'=±1"	X.X'=±.5"		
SURFACE FINISH		125	SMOOTH ALL SHARP EDGES	
NOT TO EXCEED			CLEAN ALL WELDS	
THIS PRINT AND ALL INFORMATION WITHIN BELONGS TO RACINE RAILROAD PRODUCTS				
RACINE RAILROAD PRODUCTS				
RACINE, WISCONSIN USA				
DESCRIPTION				
INSTRUCTIONS, ATPI				
DUAL PO CHK VLV KIT				
MATERIAL TYPE				
SEE BOM				
USED ON	717640	SCALE	DATE	
		1:12	08-23-24	
DRN	WEIGHT (LBS)	JOB NO	SHEET	
		RD150003	3 OF 3	
DWG SIZE	CATALOG	DWG NO		
D	N		800426	

